

2010

ELECTRICAL ENGINEERING

Paper 1

*Time : 3 Hours]**[Maximum Marks : 300*

INSTRUCTIONS

*Candidates should attempt **all** the questions in Parts A, B & C. However, they have to choose only **three** questions in Part D.*

Answers must be written in the medium opted (i.e. English or Kannada).

This paper has four parts :

A	20 marks
B	100 marks
C	90 marks
D	90 marks

Marks allotted to each question are indicated in each part.

SEAL

[Turn over

PART A

4×5=20

Answer *all* questions. Each question carries 5 marks.

1. (a) Find the current in the $20\ \Omega$ resistor.

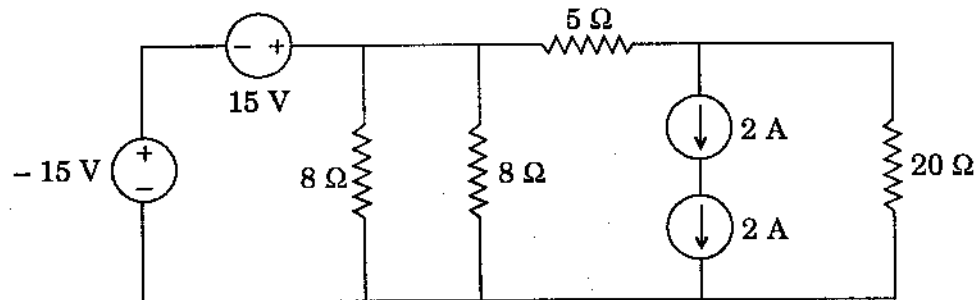

- (b) Name the equation or the law pertaining to the expressions listed below.

(i) $\mathbf{F} = Q(\mathbf{E} + \mathbf{V} \times \mathbf{B})$

(ii) $\nabla^2 V = -\frac{\rho_V}{\epsilon}$

(iii) $\int_V \mathbf{E} \cdot \mathbf{J} \, dv$

(iv) $\nabla^2 V = 0$

(v) $\oint_S \mathbf{D}_S \cdot d\mathbf{S} = Q$ enclosed by the surface

- (c) What should be the resistance in the arm DA of the Wheatstone's bridge for no deflection in the galvanometer?

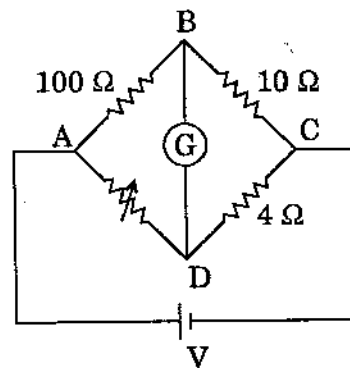

- (d) An amplifier is known to have a power gain of 40 dB. If the output is 4 W, determine the input power.

PART B

10×10=100

Answer **all** questions. Each question carries 10 marks.

2. Using Fourier transform technique, find $v_o(t)$

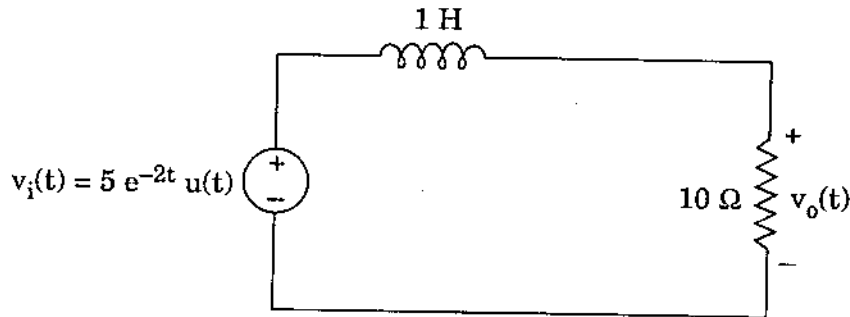

3. For what values of x , is the matrix

$$A = \begin{bmatrix} 3-x & 2 & 2 \\ 2 & 4-x & 1 \\ -2 & -4 & -1-x \end{bmatrix} \text{ singular?}$$

4. A $100 \mu\text{C}$ point charge is located in a rectangular coordinate system at $[1, 1, 1]$ m and another point charge of $50 \mu\text{C}$ is at $[-1, 0, 2]$ m. Find the vector force on the first charge.
5. Explain with sketches surfaces waves, space waves and sky waves.
6. (a) Define accuracy and precision of a measuring instrument.
- (b) What is the precision of the digital and analog meters shown below? Assume in case of analog meter, the pointer can be read to within one-fourth of the smallest scale.

9.134 V_{DC}

Digital meter display

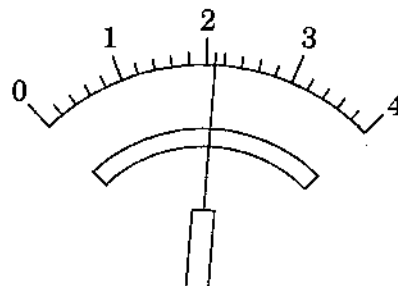

Analog meter display

[Turn over

7. A permanent magnet moving coil instrument with full scale deflection of $100 \mu\text{A}$ and a coil resistance of $1 \text{ k}\Omega$ is to be converted into a voltmeter. Determine the required multiplier resistance if the voltmeter is to measure 50 V at full scale. Also calculate the applied voltage when the instrument indicates 0.5 of full scale deflection.
8. For a class B amplifier providing a 22 V peak signal to an 8Ω load and a power supply of $V_{CC} = 25 \text{ V}$, determine the circuit efficiency.
9. Draw the hybrid equivalent circuit (small signal) of a common base amplifier shown below.

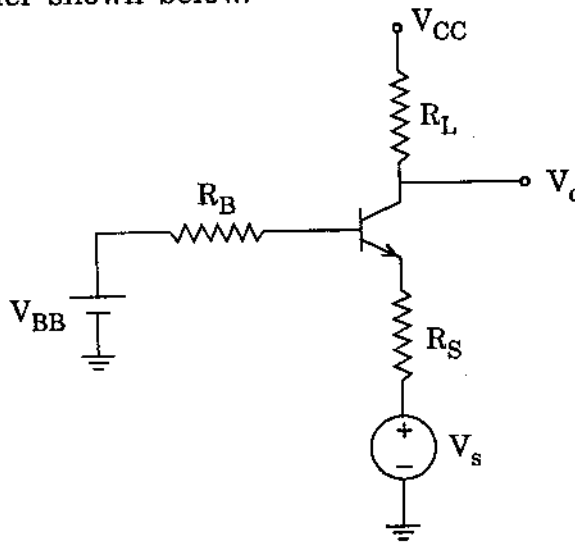

10. Why does the short circuit test essentially show only copper losses and not the iron losses in a transformer ?
11. Draw the exact stator referred equivalent circuit of a three phase induction motor and list the nomenclature of each parameter and electrical variable appearing in the circuit.

PART C

6×15=90

Answer *all* questions. Each question carries 15 marks.

12. (a) Determine the source current and inductor voltage at the instant the switch is closed.

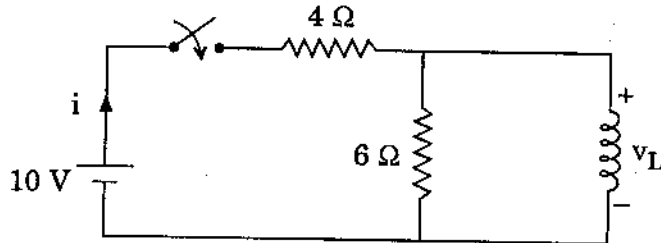

- (b) Find the transfer function $\frac{V_o(\omega)}{I_i(\omega)}$ for the circuit shown below and determine the zeros and poles.

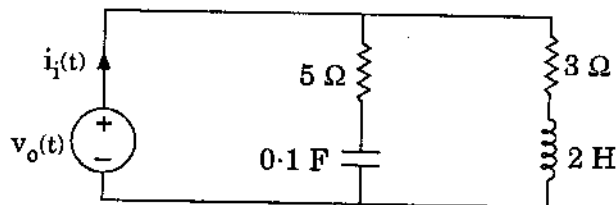

13. Using the known standard relations, show that the angle at which an electric field enters a dielectric field from air also leaves the dielectric at the same angle.
14. A Hay bridge operating at a supply frequency of 100 Hz is balanced when the components are $C_3 = 0.1 \mu\text{F}$, $R_1 = 1.26 \text{ k}\Omega$, $R_3 = 75 \Omega$ and $R_4 = 500 \Omega$. Calculate the inductance and resistance of the measured inductor. Also determine the Q factor of the coil.

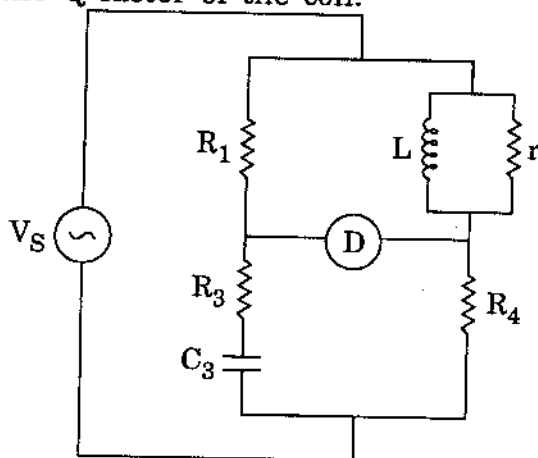

[Turn over

15. The readings on two wattmeters used to measure 3-phase power are 5000 W and 500 W, the latter reading being obtained after reversal of current coil connection. Calculate the power and power factor. Explain the reason for attaching a negative sign to the reading of the wattmeter whose current coil connection is reversed.
16. Explain the working of the monostable multivibrator, the circuit of which is shown below.

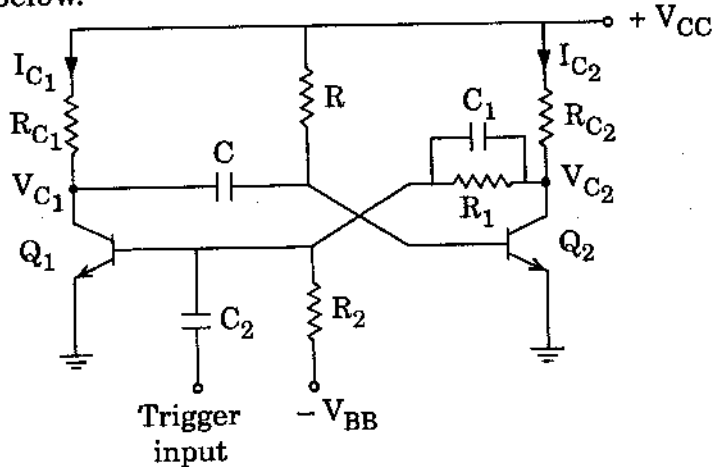

17. (a) A cumulatively compounded dc generator is operating properly as a flat compounded dc generator. The machine is then shut down and its shunt field connections are reversed.
- If this generator is turned in the same direction as before, will an output voltage be built up at its terminals? Why or why not?
 - Will the voltage build up for rotation in the opposite direction? Why or why not?
 - For the direction of rotation in which a voltage builds up, will the generator be cumulatively or differentially compounded?
- (b) A dc machine has eight poles and a rated current of 100 A. How much current will flow in each path at rated condition if the armature is (i) simplex lap wound (ii) duplex lap wound (iii) simplex wave wound?

PART D

3×30=90

Answer any **three** of the following questions. Each question carries 30 marks.

18. Find V_o using Thevenin's theorem.

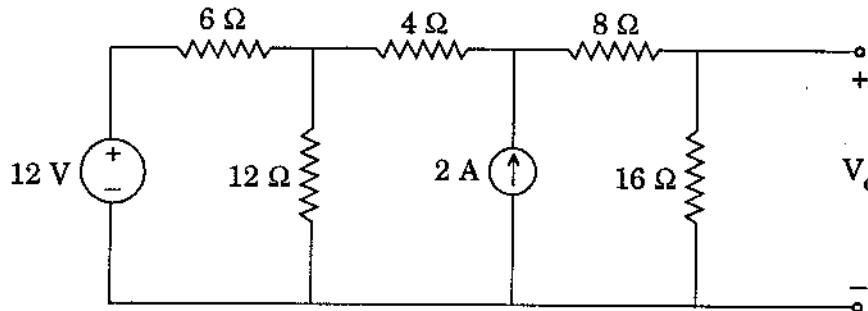

19. (a) (i) Define skin depth as applied to electromagnetic waves.
 (ii) Determine the skin depth in copper at 50 Hz if the conductivity of the copper is 5.8×10^7 S/m.
- (b) What is a uniform medium as applied to electromagnetic waves ?
- (c) Write the point form of Maxwell's equations for dynamic fields as eight scalar quantities in cartesian coordinates.
20. (a) With reference to block diagram and timing diagram explain the working of a ramp type digital voltmeter.
- (b) Find the limits between which the value of resistance is guaranteed by the manufacturer if the nominal magnitude of a resistor is 100Ω with a limiting error of $\pm 8 \Omega$.

[Turn over

- (c) Determine the rms value, frequency and phase difference between the two waveforms shown in the figure.

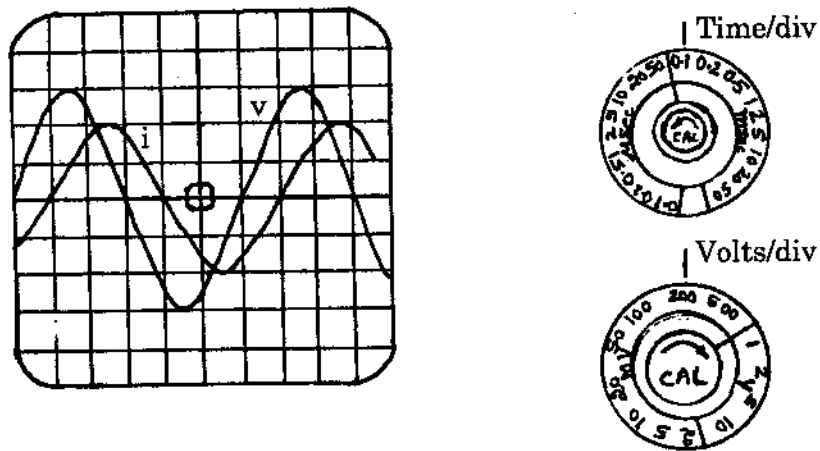

21. (a) For the network shown in the figure, determine base current, collector current, V_E and V_{CE} . Assume $V_{BE} = 0.7$ V.

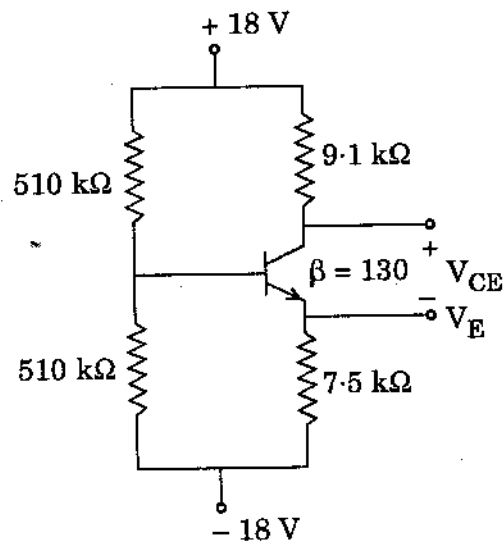

- (b) List four common advantages and one common disadvantage of all types of negative feedback in transistor amplifiers.

22. (a) A 5 kVA, 480/120 V conventional transformer is to be used as an auto transformer to supply power from a 600 V source to a 120 V load. Consider the transformer to be ideal, and assume that all insulation can handle 600 V.
- (i) Sketch the transformer connection for the required voltages.
 - (ii) Find the kVA rating of the auto transformer.
 - (iii) Find the rated primary and secondary currents of the auto transformer.
- (b) Each full pitch coil of a double layer wound, 16 pole, 144 slot, 3-phase, star connected synchronous generator has 10 turns. The rotor is driven at a speed of 375 rpm. The flux/pole is 25 mWb and each phase winding has two parallel paths. Determine the line voltage.

SEAL

2010

ELECTRICAL ENGINEERING

Paper 2

*Time : 3 Hours]**[Maximum Marks : 300*

INSTRUCTIONS

*Candidates should attempt **all** the questions in Parts A, B & C. However, they have to choose only **three** questions in Part D.*

Answers must be written in the medium opted (i.e. English or Kannada).

This paper has four parts :

A	20 marks
B	100 marks
C	90 marks
D	90 marks

Marks allotted to each question are indicated in each part.

SEAL

[Turn over

PART A

4×5=20

Answer all questions. Each question carries 5 marks.

1. (a) The frequency and induced voltage in the rotor of a certain six pole wound rotor induction motor, whose shaft is blocked are 50 Hz and 100 V respectively. Determine the corresponding values when the rotor is running at 900 r.p.m.
- (b) Calculate the length of the antenna corresponding to quarter wavelength of the frequency 500 kHz.
- (c) State in which quadrants a machine operates
 - (i) as a brake
 - (ii) as a motor
 - (iii) as a generator
- (d) List five types of communication transmission lines in use.

PART B

10×10=100

Answer all 10 questions. Each question carries 10 marks.

2. Determine the value of the error rate factor K of the given block diagram so that the damping ratio of the system is 0.6.

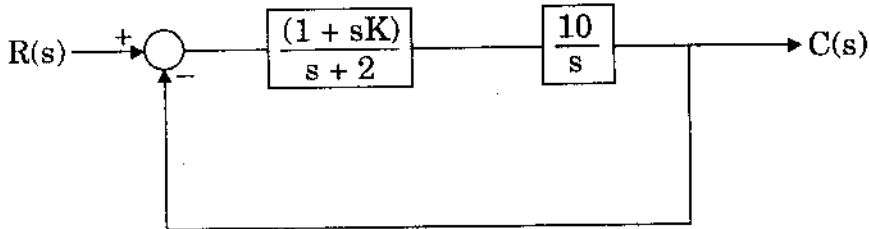

Fig. Q. 2

3. What is commutation as applied to thyristor ? Distinguish between natural and forced commutation. List four types of forced commutation.
4. A 50 kW, 440 V, 50 Hz, 2 pole induction motor has a slip of 6 percent when operating at full load condition. At full load condition, the friction and windage losses are 520 W and the core losses are 500 W. Find the load torque and induced torque.
5. A 500 kVA, 2300 V, 3 phase, star connected, synchronous generator is operated at its rated speed to obtain its rated no load voltage. When short circuit is established the phase current is 150 A. The resistance of each phase is 0.5 Ω . Determine the percent voltage regulation when the generator delivers the rated load at its rated voltage and 0.8 pf leading.
6. Calculate the relative weights of copper required for the distributor cables in a low voltage direct current, 3 wire system and a 3 phase, 4 wire system. Assume the same voltage at consumer's terminals, the same percentage loss, unity power factor and balanced load. Neglect loss in the middle wires which are of half the cross-section of corresponding outers.
7. In a short circuit test on a circuit breaker the following data was obtained on a frequency transient. Peak restriking voltage = 120 kV.
Time to reach the Peak restriking voltage = 60 μ s.
Determine the average rate of rise of restriking voltage and the natural frequency of the circuit.

[Turn over

8. Estimate the percent efficiency of high frequency induction furnace which takes 12 minutes to melt 2.5 kg of aluminium, the input to the furnace being 3.75 kW. The initial temperature is 20°C, specific heat of aluminium 880 J/kg/C, melting point 650°C, Latent heat of fusion 32 kJ/kg.
9. (a) What functions does an antenna fulfill ? What type of antenna radiates in and receives from all directions at once ?
- (b) A half wave dipole antenna is capable of radiating 1 kW and has a 2.15 dB gain over an isotropic antenna. How much power must be delivered to the isotropic antenna to match the field strength directional antenna ?
10. (a) What is direct coupling of amplifiers ? What are the applications of direct coupled amplifiers ?
- (b) What are the advantages and disadvantages of the D.C. amplifier ?
11. List 5 factors that cause the failure of insulators.

PART C

6×15=90

Answer **all** questions. Each question carries 15 marks.

12. Obtain the transfer function relating $C(s)$ and $R(s)$ of the system shown.

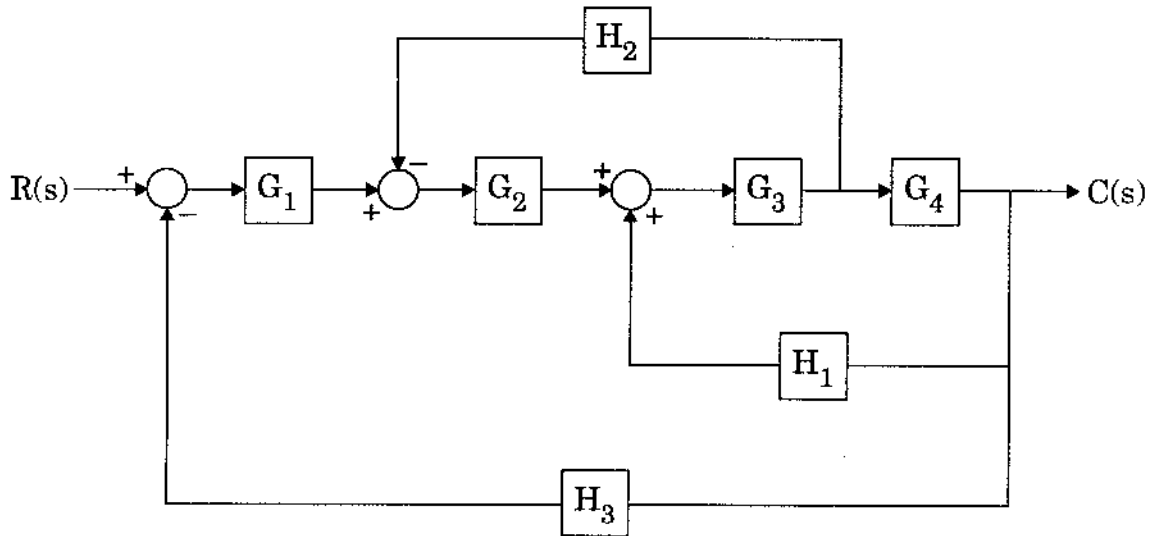

Fig. Q. 12

13. (a) Draw the block diagram of a regulated power supply system and explain the function of each block.
- (b) The delay angle of a single phase thyristor converter with a resistive load is $\frac{\pi}{2}$. Determine the rectification efficiency.
14. A 480 V, 200 kVA, 0.8 pf lagging, 2 pole star connected synchronous generator has a synchronous reactance of 0.25Ω and armature resistance of 0.03Ω . At rated speed, the friction and windage losses are 6 kW and its core losses are 4 kW. The field circuit has a dc voltage of 200 V and the maximum field current is 10 A. The resistance of the field circuit is adjustable over the range from 20 to 200 Ω . The data corresponding to open circuit characteristic of the generator is as follows.

Voltage (line) in volts :	0	120	264	360	420	480	540	557.6	570
Field current, A :	0	0.9	2.0	3.0	3.7	4.6	6.2	7.0	8.0

- Determine (a) the field current required to make the terminal voltage equal to 480 V when the generator is running at rated condition and (b) the power that the generator's prime mover is capable of supplying.

[Turn over

15. The current flowing to the delta connected load through line R is 10 A. With the current in line R as reference and assuming that the line B is open, find the symmetrical components of the line current.
16. (a) Discuss the basic principle of operation of an impedance relay.
(b) Explain the working of a horn gap arrester.
17. Briefly explain the function of each of the blocks in the superheterodyne AM receiver.

PART D

3×30=90

Answer any **three** of the following questions. Each question carries 30 marks.

18. (a) Determine the range of K for stability of the closed loop transfer function.

$$\frac{K}{s(s^2 + s + 1)(s + 2) + K}$$

by use of Routh's stability criterion.

- (b) For unity feedback system $G(s) = \frac{K}{s(s+1)(s+2)}$, plot (on plain paper) the rough nature of the root locus showing all details on it. Comment on the stability.

19. (a) Define sub-transient period, transient period and steady state period as applied to synchronous machine. What causes the behaviour observed during individual periods after a fault occurs ?

(b) Explain why an induction motor draws large current at starting.

(c) Draw the families of inverted V-curves of a synchronous motor at no load, half load and full load showing the regions of lagging and leading power factors.

20. (a) Using nominal π model find the voltage regulation of a 250 km line, delivering 50 MVA at 0.8 pf lag, 132 kV, 50 Hz. The conductors are spaced 3 cm apart equilaterally. The conductors have a diameter of 1.6 cm and resistance of 0.11 Ω /km.

(b) What is the purpose of load flow study ? What categories of buses are used in a load flow study ? What values are specified for each type of bus ?

21. (a) Describe various methods employed for electric braking.

(b) What is tractive effort of a train ? List the factors on which the tractive effort depends.

[Turn over

- (c) Determine the tractive effort required to accelerate an electric train weighing 200 tonnes to a speed of 48 km/hour in 30 seconds up a gradient of 1 : 200. The traction resistance is 50 N/tonne, the rotational inertia is 10% of the train weight.
22. (a) A 107.6 MHz carrier is frequency modulated by a 7 kHz sine wave. The resultant FM signal has a frequency deviation of 50 kHz.
- (i) Find the carrier swing of the FM signal.
 - (ii) Determine the highest and lowest frequencies attained by the modulated signal.
 - (iii) What is the modulation index of the FM wave ?
- (b) What are waveguides ? What are the waveguide shapes ? What are the advantages and disadvantages of waveguides ?

SEAL