

Paper Specific Instructions

1. The examination is of 3 hours duration. There are a total of 60 questions carrying 100 marks. The entire paper is divided into three sections, **A**, **B** and **C**. All sections are compulsory. Questions in each section are of different types.
2. **Section – A** contains a total of 30 **Multiple Choice Questions (MCQ)**. Each MCQ type question has four choices out of which only **one** choice is the correct answer. Questions Q.1 – Q.30 belong to this section and carry a total of 50 marks. Q.1 – Q.10 carry 1 mark each and Questions Q.11 – Q.30 carry 2 marks each.
3. **Section – B** contains a total of 10 **Multiple Select Questions (MSQ)**. Each MSQ type question is similar to MCQ but with a difference that there may be **one or more than one** choice(s) that are correct out of the four given choices. The candidate gets full credit if he/she selects all the correct answers only and no wrong answers. Questions Q.31 – Q.40 belong to this section and carry 2 marks each with a total of 20 marks.
4. **Section – C** contains a total of 20 **Numerical Answer Type (NAT)** questions. For these NAT type questions, the answer is a real number which needs to be entered using the virtual keyboard on the monitor. No choices will be shown for this type of questions. Questions Q.41 – Q.60 belong to this section and carry a total of 30 marks. Q.41 – Q.50 carry 1 mark each and Questions Q.51 – Q.60 carry 2 marks each.
5. In all sections, questions not attempted will result in zero mark. In **Section – A (MCQ)**, wrong answer will result in **NEGATIVE** marks. For all 1 mark questions, 1/3 marks will be deducted for each wrong answer. For all 2 marks questions, 2/3 marks will be deducted for each wrong answer. In **Section – B (MSQ)**, there is **NO NEGATIVE** and **NO PARTIAL** marking provisions. There is **NO NEGATIVE** marking in **Section – C (NAT)** as well.
6. Only Virtual Scientific Calculator is allowed. Charts, graph sheets, tables, cellular phone or other electronic gadgets are **NOT** allowed in the examination hall.
7. The Scribble Pad will be provided for rough work.

SECTION – A
MULTIPLE CHOICE QUESTIONS (MCQ)

Q. 1 – Q.10 carry one mark each.

- Q.1 The Mesozoic Era approximately ranges from
(A) 1000-540 Ma (B) 250-65 Ma (C) 540-250 Ma (D) 65 Ma-Present
- Q.2 A trench is found at a
(A) divergent plate boundary (B) convergent plate boundary
(C) transform boundary (D) passive margin
- Q.3 The strike (in degree notation) of a bed dipping 30° towards N45W is
(A) 045-225 (B) 025-205 (C) 020-200 (D) 030-210
- Q.4 Randomly oriented ore-bearing veinlets in a mass of rock are known as
(A) en echelon veins (B) sheeted veins
(C) lode (D) stockworks
- Q.5 The diagnostic amphibole in a blueschist facies metabasalt is
(A) hornblende (B) anthophyllite (C) glaucophane (D) actinolite
- Q.6 Atoll is a geomorphic feature formed by
(A) glacial erosion (B) wind flow abrasion
(C) fluvial deposition (D) coral reef accumulation
- Q.7 Approximately 71% of the planetary mass in the solar system is concentrated in
(A) Uranus (B) Mercury (C) Saturn (D) Jupiter
- Q.8 Which of the following oil field is NOT located in the western part of India?
(A) Bombay High (B) Ankleshwar
(C) Gandhar (D) Moran
- Q.9 The most abundant element in the Earth's continental crust is
(A) silicon (B) aluminium (C) oxygen (D) iron

<https://exams.freshersnow.com/>

Q.10 Mammalian fossils are commonly found in

- (A) Haimanta Group (B) Jabalpur Group
(C) Siwalik Group (D) Uttatur Group

Q. 11 – Q. 30 carry two marks each.

Q.11 Hardness of groundwater is determined by

- (A) Mohs' scale of hardness (B) concentrations of calcium and magnesium
(C) Bernoulli equation (D) Darcy's law

Q.12 Which one of the following defines a hexagonal dipyramid?

- (A) A vertical six fold axis of symmetry
(B) A horizontal mirror plane
(C) Six vertical mirror planes at an angle of 30° with each other
(D) A mirror plane that is perpendicular to the vertical six fold axis of symmetry

Q.13 Match the twinning in **Group I** with the corresponding mineral in **Group II**.

Group I

- P. Cross-hatched
Q. Carlsbad
R. Polysynthetic
S. Brazil

Group II

1. Plagioclase
2. Microcline
3. Sanidine
4. Quartz

- | | | | |
|-----|-----|-----|-----|
| (A) | (B) | (C) | (D) |
| P-4 | P-2 | P-1 | P-2 |
| Q-2 | Q-3 | Q-2 | Q-3 |
| R-1 | R-1 | R-3 | R-4 |
| S-3 | S-4 | S-4 | S-1 |

Q.14 Evidence of Late Paleozoic glaciation is recorded in

- (A) Panchet Formation (B) Talchir Formation
(C) Motur Formation (D) Barakar Formation

Q.15 Match the landform in **Group I** with the corresponding geological process in **Group II**.

- Group I**
 P. Cinder Cone
 Q. Ox-bow lake
 R. Draas
 S. Drumlin

- Group II**
 1. Eolian
 2. Glacial
 3. Volcanic
 4. Fluvial

(A)	(B)	(C)	(D)
P-3	P-4	P-2	P-3
Q-4	Q-2	Q-4	Q-2
R-1	R-1	R-3	R-4
S-2	S-3	S-1	S-1

Q.16 Identify the fold in the given figure, where T_0 and T_α represent the axial plane thicknesses at the hinge and limb, respectively.

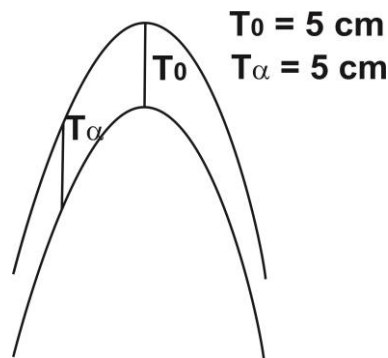

<https://exams.freshersnow.com/>

- | | |
|-----------------------|-----------------------------|
| (A) Parallel fold | (B) Similar fold |
| (C) Supratenuous fold | (D) Flattened parallel fold |

Q.17 Identify the type of fault in the given figure.

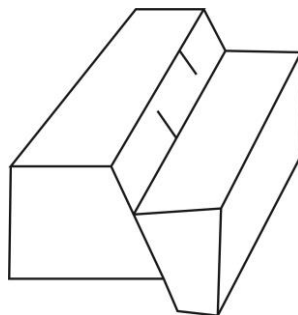

- | | |
|-------------------|-----------------------|
| (A) Normal fault | (B) Strike-slip fault |
| (C) Reverse fault | (D) Thrust fault |

Q.18 In clastic sediments, the correct order of decreasing grain size is

- (A) Boulder > pebble > silt > sand
- (B) Granule > pebble > clay > silt
- (C) Cobble > granule > silt > clay
- (D) Granule > pebble > sand > silt

Q.19 Match the primary sedimentary structure in **Group I** with the corresponding process of formation in **Group II**.

Group I

- P. Asymmetric ripples
- Q. Dish and pillar
- R. Flute cast
- S. Wavy bedding

Group II

- 1. Water escape
- 2. Bed load transportation of sediments
- 3. Deposition from alternate traction and suspension load
- 4. Scouring by turbulent eddy

- | | | | |
|-----|-----|-----|-----|
| (A) | (B) | (C) | (D) |
| P-1 | P-2 | P-2 | P-3 |
| Q-3 | Q-1 | Q-4 | Q-1 |
| R-2 | R-4 | R-1 | R-4 |
| S-4 | S-3 | S-3 | S-2 |

Q.20 The correct pair of metal and the ore mineral is

- (A) Nickel - *Sphalerite*
- (B) Tin - *Cassiterite*
- (C) Zinc - *Pyrolusite*
- (D) Lead - *Bornite*

<https://exams.freshersnow.com/>

Q.21 Match the mineral/metal deposit in **Group I** with the corresponding Indian occurrence in **Group II**.

Group I

- P. Diamond
- Q. Iron
- R. Fluorite
- S. Copper

Group II

- 1. Malanjkhand
- 2. Wajrakarur
- 3. Dalli Rajhara
- 4. Ambadongar

- | | | | |
|-----|-----|-----|-----|
| (A) | (B) | (C) | (D) |
| P-4 | P-3 | P-2 | P-2 |
| Q-3 | Q-4 | Q-1 | Q-3 |
| R-2 | R-1 | R-4 | R-4 |
| S-1 | S-2 | S-3 | S-1 |

- Q.22 The mineral sequence arranged in order of increasing degree of sharing of $(\text{SiO}_4)^{4-}$ tetrahedra is
- (A) Olivine→Tremolite→Enstatite→Quartz
 (B) Olivine→Enstatite→Tremolite→Quartz
 (C) Quartz→Tremolite→Enstatite→Olivine
 (D) Olivine→Quartz→Enstatite→Tremolite
- Q.23 The metamorphic facies series that explains oceanic subduction zone metamorphism is
- (A) Prehnite-Pumpellyite→Blueschist→Eclogite
 (B) Greenschist→Epidote amphibolite→Amphibolite→Granulite
 (C) Albite-epidote hornfels→Hornblende hornfels→Pyroxene hornfels→Sanidinite
 (D) Greenschist→Amphibolite→Granulite→Eclogite
- Q.24 The correct combination of textural feature of magmatic rocks with corresponding petrological process is
- (A) Exsolution lamellae – *Sub-solidus cooling*
 (B) Reaction rim – *Eutectic crystallization*
 (C) Graphic intergrowth – *Quenching of ultramafic lava*
 (D) Spinifex texture – *Peritectic crystallization*
- Q.25 A volcanic rock consisting of alkali feldspar (70%), sodic plagioclase (10%) and nepheline (20%) is named as
- (A) Phonolite (B) Tephrite (C) Trachyte (D) Andesite
- Q.26 Match the name of granitoid in **Group I** with the corresponding Craton in **Group II**.

Group I		Group II	
P. Closepet		1. Singhbhum	
Q. Berach		2. Bastar	
R. Dongargarh		3. Dharwar	
S. Mayurbhanj		4. Aravalli	
(A)	(B)	(C)	(D)
P-4	P-3	P-3	P-4
Q-2	Q-4	Q-4	Q-2
R-1	R-2	R-1	R-3
S-3	S-1	S-2	S-1

Q.27 Match the seismic discontinuity in **Group I** with their occurrence in Earth's interior in **Group II**.

Group I

- P. Conrad
- Q. Mohorovičić
- R. Gutenberg
- S. Lehmann

Group II

1. Between lower mantle and outer core
2. Between crust and upper mantle
3. Between inner and outer core
4. Between lower and upper crust

(A)	(B)	(C)	(D)
P-4	P-4	P-3	P-2
Q-2	Q-2	Q-2	Q-4
R-1	R-3	R-4	R-1
S-3	S-1	S-1	S-3

Q.28 Choose the correct statement:

- (A) Porosity of weathered granite is less than a crystalline granite.
- (B) Coarse sands have high porosity and high permeability.
- (C) Clays have high porosity and high permeability.
- (D) Ground water table does not fluctuate with water recharge.

Q.29 In the given profile section, **P, Q, R, S** and **T** are sedimentary rocks. Identify the type of unconformity in the sedimentary sequence.

<https://exams.freshersnow.com/>

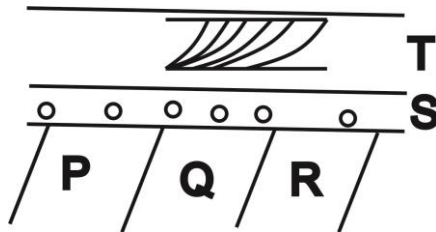

- | | |
|--------------------------|--------------------|
| (A) Angular unconformity | (B) Disconformity |
| (C) Nonconformity | (D) Paraconformity |

Q.30 Which of the following pairs is **NOT** correctly matched?

- (A) *Productus* - Brachiopoda
- (B) *Redlichia* - Arthropoda
- (C) *Belemnites* - Cephalopoda
- (D) *Gryphea* - Gastropoda

SECTION - B
MULTIPLE SELECT QUESTIONS (MSQ)

Q. 31 – Q. 40 carry two marks each.

- Q.31 Which of the following statements in relation to the solar system is/are correct?
- (A) The most abundant elements are H and He.
 (B) The abundances of elements with atomic numbers 1-50 show an overall decreasing trend.
 (C) The abundances of heavier elements (atomic number >50) are mostly higher than that of lighter elements (atomic number <50).
 (D) Elements having odd atomic numbers are more abundant than their immediate neighbours.
- Q.32 Find out the correct statement(s).
- (A) Authigenic minerals form during diagenesis of sandstone.
 (B) Heavy minerals in sandstone are good indicators of provenance.
 (C) An arkose is mineralogically more mature than a quartz arenite.
 (D) Matrix in sandstone may form by post-depositional infiltration and/or authigenic filling.
- Q.33 Which of the following is/are correctly matched?
- (A) Dendritic drainage pattern – *uniform substrate and gentle slope*
 (B) Trellis drainage pattern – *parallel valleys and ridges*
 (C) Radial drainage pattern – *uniform flat topography*
 (D) Rectangular drainage pattern – *joints and faults*
- Q.34 A northerly dipping fault (F-F) has displaced beds **P**, **Q** and **R**. The thickness of the beds across the fault is same. Identify the fault type(s).

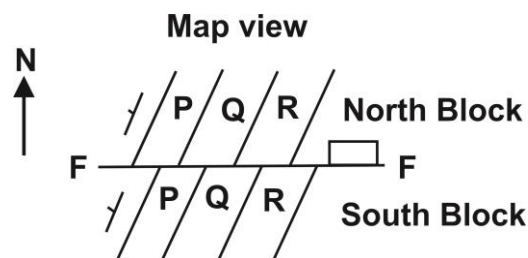

- (A) Dextral fault
 (B) Reverse fault
 (C) Normal fault
 (D) Sinistral fault

Q.35 A bedding plane, pictorially represented at X, will be plotted in stereonet as

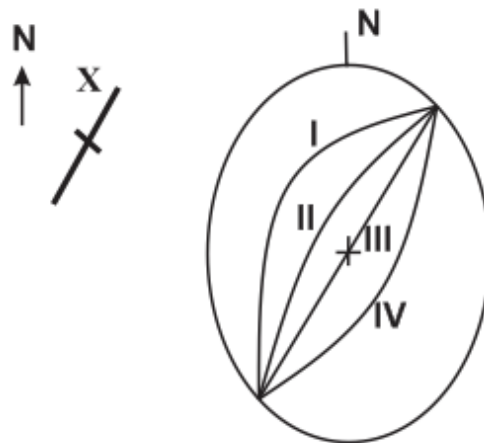

- (A) I (B) II (C) III (D) IV

Q.36 Choose the correct statement(s):

- (A) Stratiform chromite deposits form by weathering of ultramafic rocks.
 (B) Skarn deposits mostly form in calcareous host rocks in contact with felsic intrusives.
 (C) Nickeliferous laterite is a type of placer deposit.
 (D) Gold-bearing vein deposits can form from hydrothermal solutions.

<https://exams.freshersnow.com/>

Q.37 Under crossed polars, a mineral remains dark at all stages of rotation of the microscope stage. Which of the following statement(s) is/are **NOT** correct?

- (A) The mineral is isotropic.
 (B) The mineral is biaxial with an optic orientation corresponding to the principal section of the indicatrix.
 (C) The mineral is biaxial with an optic orientation containing the Y-vibration direction only.
 (D) The mineral is uniaxial with an orientation perpendicular to the optic axis.

- Q.38 A schematic deformation (D)-metamorphism (M)-time map of a metamorphic belt is shown below. The belt recorded two phases of deformation, D_1 - D_2 and attendant schistositities, S_1 - S_2 and metamorphism, M_1 - M_2 . The metamorphic minerals stable during these events are shown by solid lines.
- On the basis of this information, which of the following statement(s) is/are correct?

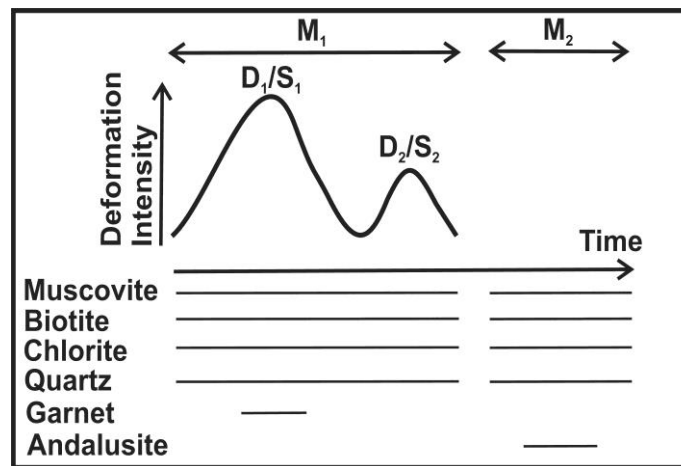

- (A) M_1 and M_2 events refer to regional and contact metamorphism, respectively.
- (B) The S_1 schistosity developed as a crenulation cleavage.
- (C) Garnet grew syntectonic with D_1 .
- (D) Andalusite grew during the waning phase of D_2 .
- Q.39 Choose the correct statement(s):
- (A) Gravity dam is a rigid structure, straight or slightly curved in places.
- (B) Arch dams are commonly built on very strong foundations.
- (C) Buttress dam chiefly consists of reinforced concrete slab that slopes upstream.
- (D) Earth dams have a concrete wall curved with convex face pointed towards the upstream.
- Q.40 Choose the correct pair(s):
- (A) Proterozoic – *Origin of flowering plants*
- (B) Paleozoic – *Origin of amphibians*
- (C) Mesozoic – *Acme of trilobites*
- (D) Cenozoic – *Dominance of mammals*

<https://exams.freshersnow.com/>

SECTION – C

NUMERICAL ANSWER TYPE (NAT)

Q. 41 – Q. 50 carry one mark each.

- Q.41 The wt.% (correct to two decimal places) of Cu in chalcopyrite (CuFeS_2) (atomic weight of Cu=63.55, Fe=55.85, S=32.07) is _____
- Q.42 The general formula of an amphibole mineral is $\text{A}_{0-1}\text{B}_2\text{C}_5\text{T}_8\text{O}_{22}(\text{OH})_2$, where A, B, C and T are cationic sites with different co-ordination numbers as stated below:
 A=12, B=6-8, C=6, T=4.
 The amount of octahedral Al in an amphibole of composition $\text{Na}_{0.6}\text{Ca}_2\text{Mg}_{3.8}\text{Al}_{3.0}\text{Si}_{6.2}\text{O}_{22}(\text{OH})_2$ is _____
- Q.43 In the block diagram, the net slip (=100 m) is resolved into strike slip (s) and dip slip (d) components. The value (in m, correct to two decimal places) of “s” is _____

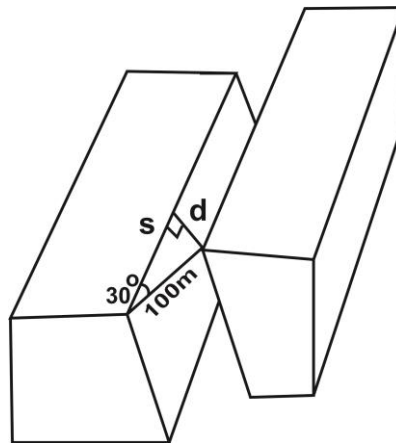

<https://exams.freshersnow.com/>

- Q.44 The true thickness (t, in m) of bed B in the given diagram is _____.

Profile view

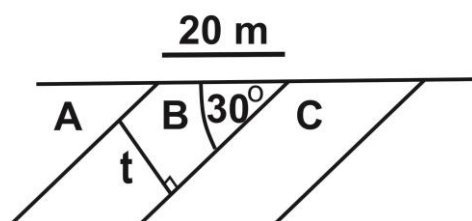

- Q.45 If (326) is the Miller Index of a crystal face, then the value of x in the corresponding Weiss Parameter of the same face, $xa: yb: zc$ is _____
- Q.46 The value of h in the Miller-Bravais Index ($\bar{4}1h0$) is _____
- Q.47 In an ocean basin, a 4 Ma old oceanic crust lies 40 km away from the ridge axis. The average velocity (in cm/yr) of the oceanic lithosphere is _____
- Q.48 An aquifer has a cross sectional area of 1000 m^2 and a hydraulic gradient of 0.01. If water is flowing from the aquifer at a rate of $10 \text{ m}^3/\text{sec}$, the hydraulic conductivity (in m/sec) of the aquifer is _____
- Q.49 According to the mineralogical phase rule, the number of minerals that can coexist at equilibrium in a 8 component chemical system with 2 degrees of freedom is _____
- Q.50 The grain density (of solids only) and bulk density (solids + voids) of a sandstone sample are 2.7 gm/cm^3 and 2.3 gm/cm^3 , respectively. The total porosity (in %, correct to two decimal places) of the sample is _____

<https://exams.freshersnow.com/>

Q. 51 – Q. 60 carry two marks each.

- Q.51 In an undeformed and normal stratigraphic succession, a dolerite dyke was emplaced before deposition of sandstone B. The difference between the maximum ages (in Myr) of deposition of sandstone A and sandstone B is _____

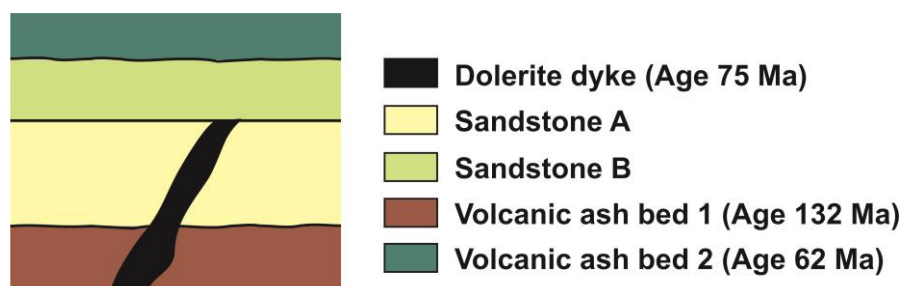

Q.52 A coal seam occurs in a stratigraphic sequence as shown in the figure. If a vertical borehole is drilled at location B, the coal seam will be intersected at a depth (in m) of ____

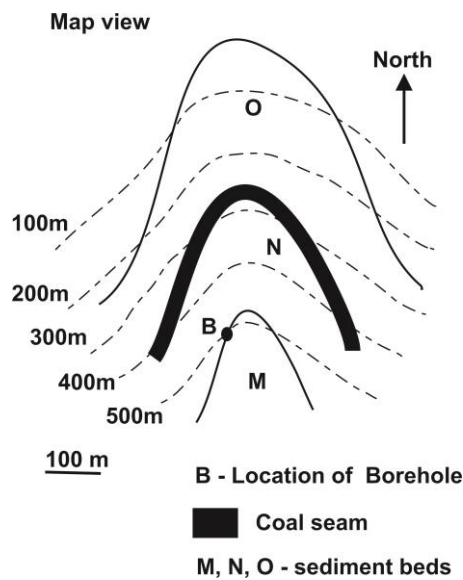

Q.53 A set of sedimentary rocks A, B and C are affected by a fault F-F. The amount of vertical throw (in m) along the fault is ____

Geological map with contour lines

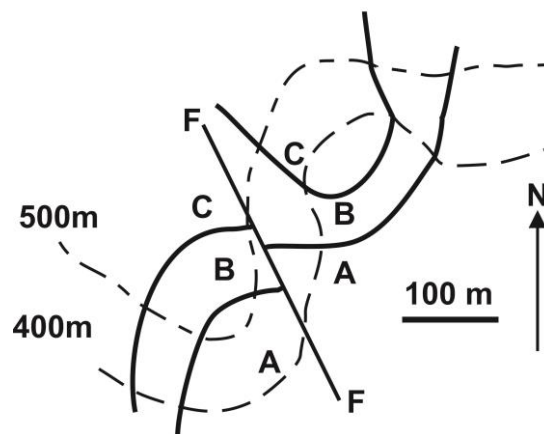

Q.54 The retardation of a uniaxial negative mineral of thickness 0.03 mm is 5160 nm in its principal section of indicatrix. If the refractive index corresponding to the E-ray is 1.486, the value of the refractive index (correct to three decimal places) of the O-ray is ____

Q.55 A spherical ore body (diameter=40m) has 7% metal content and density of 3300 kg/m³. The reserve (in tonne) of the ore body is ____

Q.56 From the data shown in the table, the weighted mean size (in micrometer, correct to two decimal places) of the sediment population is _____.

Grain size (micrometer)	Dry sediment weight (in gram)
4	50
20	75
40	125
60	50

Q.57 Consider the schematic isobaric T-X phase diagram in the binary forsterite (Fo)-fayalite (Fa) chemical system. If there is equilibrium crystallization of melt (L), the wt.% of olivine crystallized from a melt of composition “a” at a temperature T2 is _____

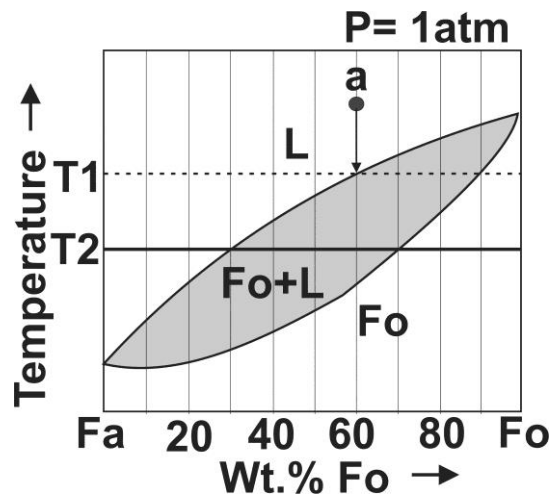

<https://exams.freshersnow.com/>

- Q.58 Consider a schematic isobaric ternary phase diagram A-B-C, shown below. The diagram, which is contoured with isopleths of liquidus temperatures (in °C), reveals crystallization behaviour of melt (L) of different compositions during cooling. When a melt of composition “a” lies at a temperature of 1800°C, the variance (or degree of freedom) of the magmatic system is _____

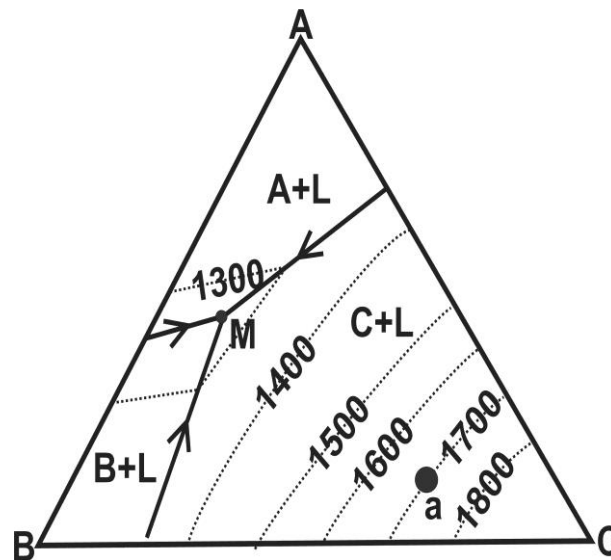

- Q.59 An eclogite consists of garnet (60%) and omphacite (40%), where the mineral abundances are in mole %. X_{Mg} [=Mg/(Mg+Fe²⁺)] of garnet and omphacite is 0.50 and 0.75, respectively. The X_{Mg} of eclogite is _____

- Q.60 A harzburgite contains pure forsterite and pure enstatite in a molecular ratio of 60:40. The mole % of MgO in the rock is _____

END OF THE QUESTION PAPER