



Telangana State Council Higher Education

Notations :

- 1.Options shown in **green** color and with  icon are correct.
- 2.Options shown in **red** color and with  icon are incorrect.

Question Paper Name :	Electronics and Communication Engineering 24th Sept 2020 Shift 1
Subject Name :	Electronics and Communication Engineering
Creation Date :	2020-09-24 15:58:27
Duration :	120
Total Marks :	120
Display Marks:	No
Share Answer Key With Delivery Engine :	Yes
Actual Answer Key :	Yes
Calculator :	None
Magnifying Glass Required? :	No
Ruler Required? :	No
Eraser Required? :	No
Scratch Pad Required? :	No
Rough Sketch/Notepad Required? :	No
Protractor Required? :	No
Show Watermark on Console? :	Yes
Highlighter :	No
Auto Save on Console? :	Yes

Electronics and Communication Engineering

Group Number :	1
Group Id :	88039693
Group Maximum Duration :	0
Group Minimum Duration :	120

Show Attended Group? :	No
Edit Attended Group? :	No
Break time :	0
Group Marks :	120
Is this Group for Examiner? :	No

Mathematics

Section Id :	880396169
Section Number :	1
Section type :	Online
Mandatory or Optional :	Mandatory
Number of Questions :	10
Number of Questions to be attempted :	10
Section Marks :	10
Display Number Panel :	Yes
Group All Questions :	Yes
Mark As Answered Required? :	Yes
Sub-Section Number :	1
Sub-Section Id :	880396169
Question Shuffling Allowed :	Yes

Question Number : 1 Question Id : 88039611041 Question Type : MCQ Option Shuffling : Yes Display Question Number : Yes Is Question Mandatory : No Single Line Question Option : No Option Orientation : Vertical Correct Marks : 1 Wrong Marks : 0

If X is a Poisson variate with the parameter λ and if $P(X=2) = P(X=3)$, then λ

Options :

88039644161. ✘ 2

88039644162. ✔ 3

88039644163. ✖ $\frac{1}{2}$

88039644164. ✖ $\frac{1}{3}$

Question Number : 2 Question Id : 88039611042 Question Type : MCQ Option Shuffling : Yes Display Question Number : Yes Is Question Mandatory : No Single Line Question Option : No Option Orientation : Vertical

Correct Marks : 1 Wrong Marks : 0

One natural number is selected at random from the first 50 natural numbers. The probability that it is a composite number is

Options :

88039644165. ✔ $\frac{17}{25}$

88039644166. ✖ $\frac{18}{25}$

88039644167. ✖ $\frac{17}{50}$

88039644168. ✖ $\frac{8}{25}$

Question Number : 3 Question Id : 88039611043 Question Type : MCQ Option Shuffling : Yes Display Question Number : Yes Is Question Mandatory : No Single Line Question Option : No Option Orientation : Vertical

Correct Marks : 1 Wrong Marks : 0

$$\oint_{|z|=1} \frac{\cos z}{z^3} dz =$$

Options :

88039644169. ✖ πi

88039644170. ✔ $-\pi i$

88039644171. ✖ $2\pi i$

88039644172. ✖ $-2\pi i$

Question Number : 4 Question Id : 88039611044 Question Type : MCQ Option Shuffling : Yes Display Question Number : Yes Is Question Mandatory : No Single Line Question Option : No Option Orientation : Vertical Correct Marks : 1 Wrong Marks : 0

Residue of $\frac{\sin z + \sinh z}{z^5}$ at $z = 0$ is

Options :

88039644173. ✔ 0

88039644174. ✖ πi

88039644175. ✖ $-\pi i$

88039644176. ✖ $2\pi i$

Question Number : 5 Question Id : 88039611045 Question Type : MCQ Option Shuffling : Yes Display Question Number : Yes Is Question

Mandatory : No Single Line Question Option : No Option Orientation : Vertical

Correct Marks : 1 Wrong Marks : 0

$$\int_0^{\infty} \frac{\sin^2 x}{x^2} dx =$$

Options :

88039644177. ✓ $\frac{\pi}{2}$

88039644178. ✗ $\frac{\pi}{4}$

88039644179. ✗ $\frac{\pi}{6}$

88039644180. ✗ $\frac{\pi}{3}$

Question Number : 6 Question Id : 88039611046 Question Type : MCQ Option Shuffling : Yes Display Question Number : Yes Is Question

Mandatory : No Single Line Question Option : No Option Orientation : Vertical

Correct Marks : 1 Wrong Marks : 0

$$z = \sin^{-1} \left(\frac{x+y}{\sqrt{x} + \sqrt{y}} \right) \Rightarrow x \frac{\partial z}{\partial x} + y \frac{\partial z}{\partial y} =$$

Options :

88039644181. ✗ $\frac{1}{2} \cot z$

88039644182. ✓ $\frac{1}{2} \tan z$

88039644183. ✖ $\cot z$

88039644184. ✖ $\tan z$

Question Number : 7 Question Id : 88039611047 Question Type : MCQ Option Shuffling : Yes Display Question Number : Yes Is Question Mandatory : No Single Line Question Option : No Option Orientation : Vertical

Correct Marks : 1 Wrong Marks : 0

The solution of $y'' + y = 0$ satisfying $y(0) = -1, y'(0) = 1$

Options :

88039644185. ✖ $\sin x + \cos x$

88039644186. ✖ $\cos x - \sin x$

88039644187. ✖ $\sin x$

88039644188. ✔ $\sin x - \cos x$

Question Number : 8 Question Id : 88039611048 Question Type : MCQ Option Shuffling : Yes Display Question Number : Yes Is Question Mandatory : No Single Line Question Option : No Option Orientation : Vertical

Correct Marks : 1 Wrong Marks : 0

If the particular integral of $y'' - 3y' + 2y = \sin 2x$ is $k(3 \cos 2x - \sin 2x)$, then $k =$

Options :

88039644189. ✖ 10

88039644190. ✖ $\frac{1}{10}$

88039644191. ✓ $\frac{1}{20}$

88039644192. ✖ 20

Question Number : 9 Question Id : 88039611049 Question Type : MCQ Option Shuffling : Yes Display Question Number : Yes Is Question Mandatory : No Single Line Question Option : No Option Orientation : Vertical Correct Marks : 1 Wrong Marks : 0

The sum of squares of eigen values of the matrix $\begin{pmatrix} 1 & 2 & 0 \\ 2 & 0 & 1 \\ 0 & 1 & 2 \end{pmatrix}$ is

Options :

88039644193. ✖ 12

88039644194. ✓ 15

88039644195. ✖ 27

88039644196. ✖ 9

Question Number : 10 Question Id : 88039611050 Question Type : MCQ Option Shuffling : Yes Display Question Number : Yes Is Question Mandatory : No Single Line Question Option : No Option Orientation : Vertical Correct Marks : 1 Wrong Marks : 0

Newton's iteration formula to solve the cubic equation $x^3 + 2x + 1 = 0$ is $x_{n+1} - x_n =$

Options :

88039644197. ✓ $-\left(\frac{x_n^3 + 2x_n + 1}{3x_n^2 + 2}\right)$

88039644198. ✘ $-\left(\frac{3x_n^2 + 2}{x_n^3 + 2x_n} + 1\right)$

88039644199. ✘ $\frac{x_n^3 + 2x_n + 1}{3x_n^2 + 2}$

88039644200. ✘ $\frac{3x_n^2 + 2}{x_n^3 + 2x_n + 1}$

Electronics and Communication Engineering

Section Id :	880396170
Section Number :	2
Section type :	Online
Mandatory or Optional :	Mandatory
Number of Questions :	110
Number of Questions to be attempted :	110
Section Marks :	110
Display Number Panel :	Yes
Group All Questions :	Yes
Mark As Answered Required? :	Yes
Sub-Section Number :	1
Sub-Section Id :	880396170
Question Shuffling Allowed :	Yes

Question Number : 11 Question Id : 88039611051 Question Type : MCQ Option Shuffling : Yes Display Question Number : Yes Is Question Mandatory : No Single Line Question Option : No Option Orientation : Vertical

Correct Marks : 1 Wrong Marks : 0

Determine the maximum input signal to be applied to an op-amp to get distortion free output. If the op-amp used is an inverting amplifier with a gain of 50 and maximum output amplitude obtained is 4.5V sine wave?

Options :

88039644201. ✘ 1.7 V

88039644202. ✔ 0.18 V

88039644203. ✘ 1.85 V

88039644204. ✘ 1.50 V

Question Number : 12 Question Id : 88039611052 Question Type : MCQ Option Shuffling : Yes Display Question Number : Yes Is Question Mandatory : No Single Line Question Option : No Option Orientation : Vertical

Correct Marks : 1 Wrong Marks : 0

In the circuit shown below, the input voltage v_i is 0.4 V. The output voltage v_0 is

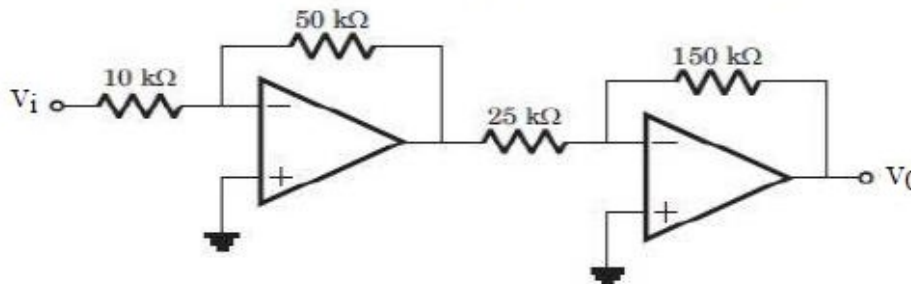

Options :

88039644205. ✔ 12 V

88039644206. ✘ -12 V

88039644207. ✘ 10 V

88039644208. ✘ -10 V

Question Number : 13 Question Id : 88039611053 Question Type : MCQ Option Shuffling : Yes Display Question Number : Yes Is Question Mandatory : No Single Line Question Option : No Option Orientation : Vertical Correct Marks : 1 Wrong Marks : 0

Compute the output voltage from the following circuit diagram?

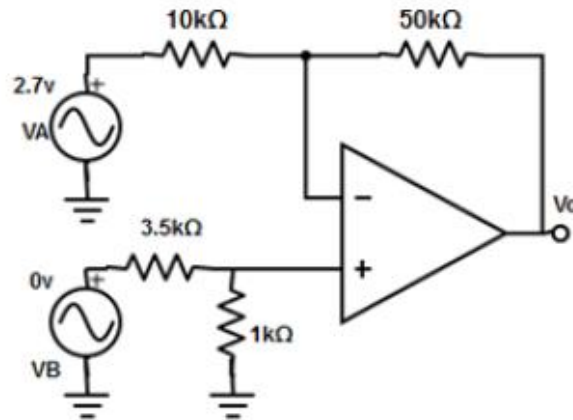

Options :

88039644209. ✘ -12 V

88039644210. ✔ -13.5 V

88039644211. ✘ 17.5 V

88039644212. ✘ 15 V

Question Number : 14 Question Id : 88039611054 Question Type : MCQ Option Shuffling : Yes Display Question Number : Yes Is Question Mandatory : No Single Line Question Option : No Option Orientation : Vertical Correct Marks : 1 Wrong Marks : 0

In the op-amp circuit given below, the load current ' I_L ' is

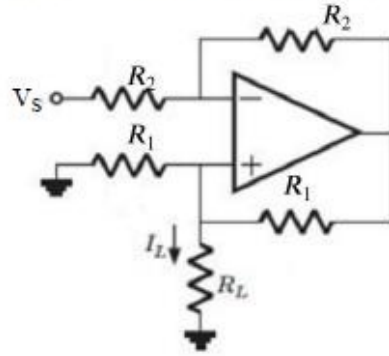

Options :

88039644213. ✘ v_s/R_2

88039644214. ✘ $-v_s/R_L$

88039644215. ✘ v_s/R_L

88039644216. ✔ $-v_s/R_1$

Question Number : 15 Question Id : 88039611055 Question Type : MCQ Option Shuffling : Yes Display Question Number : Yes Is Question Mandatory : No Single Line Question Option : No Option Orientation : Vertical Correct Marks : 1 Wrong Marks : 0

Two silicon diodes, with a forward voltage drop of 0.7 V , are used in the circuit shown in the figure below. The range of input voltage V_i for which the output voltage $V_0 = V_i$ is

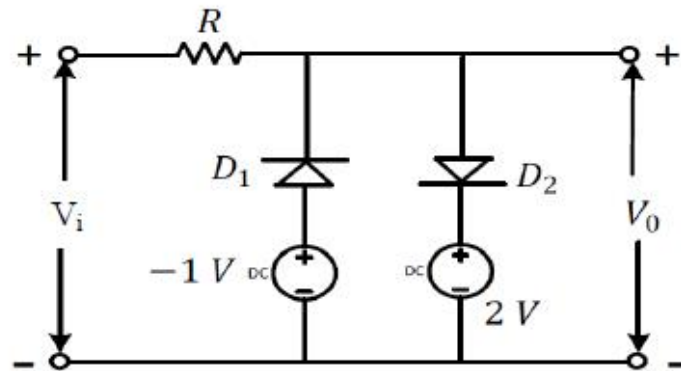

Options :

88039644217. ✘ $-0.3\text{ V} < V_i < 1.3\text{ V}$

88039644218. ✔ $-1.7\text{ V} < V_i < 2.7\text{ V}$

88039644219. ✘ $-0.3\text{ V} < V_i < 2\text{ V}$

88039644220. ✘ $-1.0\text{ V} < V_i < 2.0\text{ V}$

Question Number : 16 Question Id : 88039611056 Question Type : MCQ Option Shuffling : Yes Display Question Number : Yes Is Question Mandatory : No Single Line Question Option : No Option Orientation : Vertical Correct Marks : 1 Wrong Marks : 0

Consider the following statements S1 and S2

S1: The ' β ' of a bipolar transistor reduces if the base width is increased

S2: The ' β ' of a bipolar transistor increases if the doping concentration in the base is increased.

Which one of the following is correct?

Options :

88039644221. ✖ S1 is false and S2 is true

88039644222. ✖ Both are true

88039644223. ✖ Both are false

88039644224. ✔ S1 is true and S2 is false

Question Number : 17 Question Id : 88039611057 Question Type : MCQ Option Shuffling : Yes Display Question Number : Yes Is Question Mandatory : No Single Line Question Option : No Option Orientation : Vertical

Correct Marks : 1 Wrong Marks : 0

For a BJT, the common – base current gain $\alpha = 0.95$ and the collector base junction reverse bias saturation current $I_{CO} = 0.6\mu A$. This BJT is connected in the common emitter mode and operated in the active region with a base drive current $I_B = 20\mu A$. The collector current I_C for this mode of operation is

Options :

88039644225. ✖ 0.35 mA

88039644226. ✔ 0.392 mA

88039644227. ✖ 0.450 mA

88039644228. ✖ 0.492 mA

Question Number : 18 Question Id : 88039611058 Question Type : MCQ Option Shuffling : Yes Display Question Number : Yes Is Question Mandatory : No Single Line Question Option : No Option Orientation : Vertical

Correct Marks : 1 Wrong Marks : 0

For the feedback circuit of voltage series feedback amplifier, find the feedback voltage for the specifications: $R_1 = 1 \text{ k}\Omega$, $R_F = 10 \text{ k}\Omega$ and $V_o = 25 \text{ V}$

Options :

88039644229. ✖ 12.5 V

88039644230. ✖ 22 V

88039644231. ✖ 0.9 V

88039644232. ✔ 2.3 V

Question Number : 19 Question Id : 88039611059 Question Type : MCQ Option Shuffling : Yes Display Question Number : Yes Is Question Mandatory : No Single Line Question Option : No Option Orientation : Vertical

Correct Marks : 1 Wrong Marks : 0

Consider the following two situations about the internal conditions in an n – channel MOSFET operating in the active region

S1: The inversion charge increases from source to drain

S2 : The channel potential decreases from source to drain

Which of the following is correct?

Options :

88039644233. ✖ S1 is true

88039644234. ✔ S1 and S2 are false

88039644235. ✖ S1 and S2 are true but S2 is not a reason for S1

88039644236. ✖ Both S1 and S2 are true and S2 is reason for S1

Question Number : 20 Question Id : 88039611060 Question Type : MCQ Option Shuffling : Yes Display Question Number : Yes Is Question Mandatory : No Single Line Question Option : No Option Orientation : Vertical Correct Marks : 1 Wrong Marks : 0

The value of C required for sinusoidal oscillation of frequency of 2 kHz in the circuit shown below is

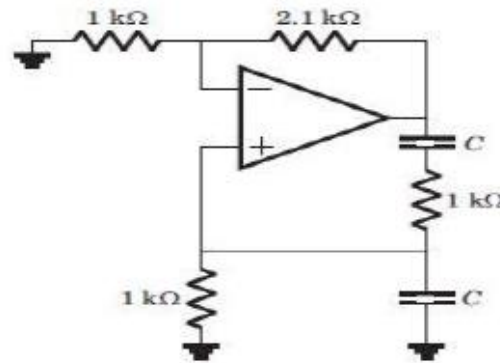

Options :

88039644237. ✓ $1/(4\pi) \mu\text{F}$

88039644238. ✗ $2\pi \mu\text{F}$

88039644239. ✗ $\sqrt{6}/(2\pi) \mu\text{F}$

88039644240. ✗ $2\pi\sqrt{6} \mu\text{F}$

Question Number : 21 Question Id : 88039611061 Question Type : MCQ Option Shuffling : Yes Display Question Number : Yes Is Question Mandatory : No Single Line Question Option : No Option Orientation : Vertical Correct Marks : 1 Wrong Marks : 0

Poynting vector gives

Options :

88039644241. ✖ Magnitude of rate of energy flow
88039644242. ✖ Integral of electric field
88039644243. ✖ Intensity of magnetic field and its direction
88039644244. ✔ Rate of energy flow and its direction

Question Number : 22 Question Id : 88039611062 Question Type : MCQ Option Shuffling : Yes Display Question Number : Yes Is Question Mandatory : No Single Line Question Option : No Option Orientation : Vertical Correct Marks : 1 Wrong Marks : 0

Which of the following is the Laplace equation?

Options :

88039644245. ✖ $\nabla^2 V = -\rho/\epsilon$
88039644246. ✔ $\nabla^2 V = 0$
88039644247. ✖ $\nabla^2 V = -4\pi\rho$
88039644248. ✖ $\nabla^2 V = -4\pi\sigma$

Question Number : 23 Question Id : 88039611063 Question Type : MCQ Option Shuffling : Yes Display Question Number : Yes Is Question Mandatory : No Single Line Question Option : No Option Orientation : Vertical Correct Marks : 1 Wrong Marks : 0

Which one of the following conditions will guarantee a distortion less transmission line

Options :

88039644249. ✓ $R = 0, G = 0$

88039644250. ✗ $L = 0, R = 0$

88039644251. ✗ $R \ll \omega L, G \gg \omega C$

88039644252. ✗ $R \gg \omega L, G \ll \omega C$

Question Number : 24 Question Id : 88039611064 Question Type : MCQ Option Shuffling : Yes Display Question Number : Yes Is Question Mandatory : No Single Line Question Option : No Option Orientation : Vertical Correct Marks : 1 Wrong Marks : 0

For which of the following statement does the Stokes' theorem is applicable

Options :

88039644253. ✗ Static field only

88039644254. ✓ Both static & time varying fields

88039644255. ✗ Time varying fields only

88039644256. ✗ Electric fields only

Question Number : 25 Question Id : 88039611065 Question Type : MCQ Option Shuffling : Yes Display Question Number : Yes Is Question Mandatory : No Single Line Question Option : No Option Orientation : Vertical Correct Marks : 1 Wrong Marks : 0

If a current element is z-directed, then vector magnetic potential is

Options :

88039644257. ✗ X – directed

88039644258. ✖ Y- directed

88039644259. ✖ θ – directed

88039644260. ✔ Z – directed

Question Number : 26 Question Id : 88039611066 Question Type : MCQ Option Shuffling : Yes Display Question Number : Yes Is Question Mandatory : No Single Line Question Option : No Option Orientation : Vertical

Correct Marks : 1 Wrong Marks : 0

A hollow rectangular waveguide acts as a _____

Options :

88039644261. ✔ High pass filter

88039644262. ✖ Band reject filter

88039644263. ✖ Band pass filter

88039644264. ✖ Low pass filter

Question Number : 27 Question Id : 88039611067 Question Type : MCQ Option Shuffling : Yes Display Question Number : Yes Is Question Mandatory : No Single Line Question Option : No Option Orientation : Vertical

Correct Marks : 1 Wrong Marks : 0

If a line is terminated with the load impedance equals to the characteristic's impedance,

then VSWR (Voltage Standing Wave Ratio) is

Options :

88039644265. ✖ 0

88039644266. ✔ 1

88039644267. ✖ ∞

88039644268. ✖ -1

Question Number : 28 Question Id : 88039611068 Question Type : MCQ Option Shuffling : Yes Display Question Number : Yes Is Question Mandatory : No Single Line Question Option : No Option Orientation : Vertical Correct Marks : 1 Wrong Marks : 0

When an EM wave is incident from a free space to a conducting medium, then it is

Options :

88039644269. ✖ Fully transmitted

88039644270. ✔ Fully reflected

88039644271. ✖ Partially transmitted

88039644272. ✖ Partially reflected

Question Number : 29 Question Id : 88039611069 Question Type : MCQ Option Shuffling : Yes Display Question Number : Yes Is Question Mandatory : No Single Line Question Option : No Option Orientation : Vertical Correct Marks : 1 Wrong Marks : 0

Which of the following is the unit for Permeability?

Options :

88039644273. ✖ Henry x Meter²

88039644274. ✔ Henry / Meter

88039644275. ✖ Henry / Meter²

88039644276. ✖ Henry x Meter

Question Number : 30 Question Id : 88039611070 Question Type : MCQ Option Shuffling : Yes Display Question Number : Yes Is Question Mandatory : No Single Line Question Option : No Option Orientation : Vertical

Correct Marks : 1 Wrong Marks : 0

The dominant mode of rectangular wave guide is

Options :

88039644277. ✖ TE11

88039644278. ✖ TM11

88039644279. ✖ TE01

88039644280. ✔ TE10

Question Number : 31 Question Id : 88039611071 Question Type : MCQ Option Shuffling : Yes Display Question Number : Yes Is Question Mandatory : No Single Line Question Option : No Option Orientation : Vertical

Correct Marks : 1 Wrong Marks : 0

The Transverse magnetic wave traveling in z-direction satisfies which of the following equation

Options :

88039644281. ✖ $E_z = 0, H_z = 0$

88039644282. ✖ $E_z = 0, H_z \neq 0$

88039644283. ✔ $E_z \neq 0, H_z = 0$

88039644284. ✖ $E_z \neq 0, H_z \neq 0$

Question Number : 32 Question Id : 88039611072 Question Type : MCQ Option Shuffling : Yes Display Question Number : Yes Is Question Mandatory : No Single Line Question Option : No Option Orientation : Vertical

Correct Marks : 1 Wrong Marks : 0

The intrinsic impedance of free space is

Options :

88039644285. ✖ 76π Ohms

88039644286. ✖ 73 Ohms

88039644287. ✔ 120π Ohms

88039644288. ✖ 300 Ohms

Question Number : 33 Question Id : 88039611073 Question Type : MCQ Option Shuffling : Yes Display Question Number : Yes Is Question Mandatory : No Single Line Question Option : No Option Orientation : Vertical

Correct Marks : 1 Wrong Marks : 0

The complex permittivity is given by $5-10j$. Find the loss tangent.

Options :

88039644289. ✖ $1/2$

88039644290. ✖ $-1/2$

88039644291. ✔ 2

88039644292. ✖ -2

Question Number : 34 Question Id : 88039611074 Question Type : MCQ Option Shuffling : Yes Display Question Number : Yes Is Question Mandatory : No Single Line Question Option : No Option Orientation : Vertical Correct Marks : 1 Wrong Marks : 0

The phase velocity of a wave having a phase constant of 4 units and a frequency of 3×10^9 radian/sec is (in 10^8 order)

Options :

88039644293. ✖ 1.33

88039644294. ✖ 6.5

88039644295. ✔ 7.5

88039644296. ✖ 1.75

Question Number : 35 Question Id : 88039611075 Question Type : MCQ Option Shuffling : Yes Display Question Number : Yes Is Question Mandatory : No Single Line Question Option : No Option Orientation : Vertical Correct Marks : 1 Wrong Marks : 0

Identify the polarisation of the wave given, $E_x = 2 \cos\omega t$ and $E_y = 2 \sin\omega t$. The phase difference is $+90^\circ$.

Options :

88039644297. ✖ Left hand circularly polarised

88039644298. ✔ Right hand circularly polarised

88039644299. ✖ Left hand elliptically polarised

88039644300. ✖ Right hand elliptically polarised

Question Number : 36 Question Id : 88039611076 Question Type : MCQ Option Shuffling : Yes Display Question Number : Yes Is Question Mandatory : No Single Line Question Option : No Option Orientation : Vertical

Correct Marks : 1 Wrong Marks : 0

If the characteristic impedance of a transmission line is 50Ω and reflection coefficient 0.3, then load impedance is

Options :

88039644301. ✘ 26.92Ω

88039644302. ✘ 30Ω

88039644303. ✘ 40Ω

88039644304. ✔ 92.85Ω

Question Number : 37 Question Id : 88039611077 Question Type : MCQ Option Shuffling : Yes Display Question Number : Yes Is Question Mandatory : No Single Line Question Option : No Option Orientation : Vertical

Correct Marks : 1 Wrong Marks : 0

Consider an air-filled waveguide operating in the TE_{12} mode at a frequency 20% higher than the cut-off frequency. The Phase Velocity is

Options :

88039644305. ✘ $1.66 \times 10^8 \text{ m/s}$

88039644306. ✔ $5.42 \times 10^8 \text{ m/s}$

88039644307. ✘ $2.46 \times 10^8 \text{ m/s}$

88039644308. ✘ $9.43 \times 10^8 \text{ m/s}$

Question Number : 38 Question Id : 88039611078 Question Type : MCQ Option Shuffling : Yes Display Question Number : Yes Is Question Mandatory : No Single Line Question Option : No Option Orientation : Vertical

Correct Marks : 1 Wrong Marks : 0

The plane wave $E = 42 \cos(\omega t - z) u_x$ V/m in air normally hits a lossless medium

$u_r = 1$ and $\epsilon_r = 4$. The reflection coefficient is

Options :

88039644309. ✖ 1/2

88039644310. ✖ 1

88039644311. ✔ 1/3

88039644312. ✖ 0.65

Question Number : 39 Question Id : 88039611079 Question Type : MCQ Option Shuffling : Yes Display Question Number : Yes Is Question Mandatory : No Single Line Question Option : No Option Orientation : Vertical

Correct Marks : 1 Wrong Marks : 0

In a code - division multiple access (CDMA) system with $N = 16$ chips, the maximum number of users who can be assigned mutually orthogonal signature sequences is

Options :

88039644313. ✖ 8

88039644314. ✔ 16

88039644315. ✖ 4

88039644316. ✖ 32

Question Number : 40 Question Id : 88039611080 Question Type : MCQ Option Shuffling : Yes Display Question Number : Yes Is Question Mandatory : No Single Line Question Option : No Option Orientation : Vertical

Correct Marks : 1 Wrong Marks : 0

In a PCM system, if the code word length is increased from 6 to 8 bits, the signal to quantization noise ratio improves by the factor

Options :

88039644317. ✖ 1/16

88039644318. ✔ 16

88039644319. ✖ 3/16

88039644320. ✖ $\log_2 16$

Question Number : 41 Question Id : 88039611081 Question Type : MCQ Option Shuffling : Yes Display Question Number : Yes Is Question Mandatory : No Single Line Question Option : No Option Orientation : Vertical

Correct Marks : 1 Wrong Marks : 0

A modulating signal given by, $x(t) = 5\sin(4\pi 10^3 t - 10\pi \cos 2\pi 10^3 t)$ V is fed to a phase modulator with phase deviation constant $k_p = 0.5$ rad/V. If the carrier frequency is 10 kHz, the instantaneous frequency (in kHz) at $t = 0.5$ ms is

Options :

88039644321. ✖ 50

88039644322. ✔ 60

88039644323. ✖ 70

88039644324. ✖ 80

Question Number : 42 Question Id : 88039611082 Question Type : MCQ Option Shuffling : Yes Display Question Number : Yes Is Question

Mandatory : No Single Line Question Option : No Option Orientation : Vertical

Correct Marks : 1 Wrong Marks : 0

For a super heterodyne receiver, the intermediate frequency is 15 MHz and the local oscillator frequency is 3.5 GHz. If the frequency of the received signal is greater than the local oscillator frequency, then the image frequency (in MHz) is

Options :

88039644325. ✓ 3485

88039644326. ✗ 3478

88039644327. ✗ 3500

88039644328. ✗ 3445

Question Number : 43 Question Id : 88039611083 Question Type : MCQ Option Shuffling : Yes Display Question Number : Yes Is Question

Mandatory : No Single Line Question Option : No Option Orientation : Vertical

Correct Marks : 1 Wrong Marks : 0

A super heterodyne receiver operates in the frequency range of 58 MHz – 68 MHz. The intermediate frequency f_{IF} and local oscillator frequency f_{LO} are chosen such that $f_{IF} \leq f_{LO}$. It is required that the image frequencies fall outside the 58 MHz – 68 MHz band. The minimum required f_{IF} (in MHz) is

Options :

88039644329. ✓ 5

88039644330. ✗ 10

88039644331. ✗ 58

88039644332. ✖ 68

Question Number : 44 Question Id : 88039611084 Question Type : MCQ Option Shuffling : Yes Display Question Number : Yes Is Question Mandatory : No Single Line Question Option : No Option Orientation : Vertical

Correct Marks : 1 Wrong Marks : 0

Consider two independent random variables X and Y with identical distributions. The variables X and Y take values 0, 1 and 2 with probabilities, $1/2$, $1/4$ and $1/4$ respectively.

What is the conditional probability $P(X + Y = 2 | X - Y = 0)$?

Options :

88039644333. ✖ 0

88039644334. ✖ $1/16$

88039644335. ✔ $1/6$

88039644336. ✖ 1

Question Number : 45 Question Id : 88039611085 Question Type : MCQ Option Shuffling : Yes Display Question Number : Yes Is Question Mandatory : No Single Line Question Option : No Option Orientation : Vertical

Correct Marks : 1 Wrong Marks : 0

A voice-grade AWGN (additive white Gaussian noise) telephone channel has a bandwidth of 4.0 kHz and two-sided noise power spectral density $\frac{\eta}{2} = 2.5 \times 10^{-5}$ Watt per Hz. If information at the rate of 52 kbps is to be transmitted over this channel with arbitrarily small bit error rate, then the minimum bit energy E_b (in mJ/bit) necessary is

Options :

88039644337. ✔ 31.5

88039644338. ✖ 29.5

88039644339. ✖ 33.5

88039644340. ✖ 34.5

Question Number : 46 Question Id : 88039611086 Question Type : MCQ Option Shuffling : Yes Display Question Number : Yes Is Question Mandatory : No Single Line Question Option : No Option Orientation : Vertical

Correct Marks : 1 Wrong Marks : 0

A sinusoidal message signal is converted to a PCM signal using a uniform quantizer. The required signal to quantization noise ratio (SQNR) at the output of the quantizer is 20 dB.

The minimum number of bits per sample needed to achieve the desired SQNR is

Options :

88039644341. ✔ 3

88039644342. ✖ 7

88039644343. ✖ 4

88039644344. ✖ 11

Question Number : 47 Question Id : 88039611087 Question Type : MCQ Option Shuffling : Yes Display Question Number : Yes Is Question Mandatory : No Single Line Question Option : No Option Orientation : Vertical

Correct Marks : 1 Wrong Marks : 0

A sinusoidal signal of 2 kHz frequency is applied to a delta modulator. The sampling rate and step-size Δ of the delta modulator are 20,000 samples per second and 0.1 V, respectively. To prevent slope overload, the maximum amplitude of the sinusoidal signal (in Volts) is

Options :

88039644345. ✘ $1/\pi$

88039644346. ✔ $1/(2\pi)$

88039644347. ✘ $2/\pi$

88039644348. ✘ π

Question Number : 48 Question Id : 88039611088 Question Type : MCQ Option Shuffling : Yes Display Question Number : Yes Is Question Mandatory : No Single Line Question Option : No Option Orientation : Vertical

Correct Marks : 1 Wrong Marks : 0

In a 16-ary PSK, the symbol rate is 10 kbps. The bit rate is

Options :

88039644349. ✘ 160 kbps

88039644350. ✔ 40 kbps

88039644351. ✘ 2.5 kbps

88039644352. ✘ 0.625 kbps

Question Number : 49 Question Id : 88039611089 Question Type : MCQ Option Shuffling : Yes Display Question Number : Yes Is Question

Mandatory : No Single Line Question Option : No Option Orientation : Vertical

Correct Marks : 1 Wrong Marks : 0

Companding is used in PCM in order to

Options :

88039644353. ✓ Keep the quantization noise low for low-amplitude segments of a signal

88039644354. ✗ Avoid quantization noise

88039644355. ✗ Reduce the effect of impulse, or, channel noise

88039644356. ✗ Reduce the complexity of the PCM system

Question Number : 50 Question Id : 88039611090 Question Type : MCQ Option Shuffling : Yes Display Question Number : Yes Is Question

Mandatory : No Single Line Question Option : No Option Orientation : Vertical

Correct Marks : 1 Wrong Marks : 0

Which of the following type of noise becomes of great importance at high frequencies?

Options :

88039644357. ✗ Shot noise

88039644358. ✗ Random noise

88039644359. ✗ Impulse noise

88039644360. ✓ Transit-time noise

Question Number : 51 Question Id : 88039611091 Question Type : MCQ Option Shuffling : Yes Display Question Number : Yes Is Question

Mandatory : No Single Line Question Option : No Option Orientation : Vertical

Correct Marks : 1 Wrong Marks : 0

Which one of the following digital band pass modulation schemes cannot be detected non-coherently?

Options :

88039644361. ✘ FSK

88039644362. ✘ ASK

88039644363. ✔ PSK

88039644364. ✘ Sunde's BFSK

Question Number : 52 Question Id : 88039611092 Question Type : MCQ Option Shuffling : Yes Display Question Number : Yes Is Question Mandatory : No Single Line Question Option : No Option Orientation : Vertical

Correct Marks : 1 Wrong Marks : 0

To save transmitted power, the carrier of an AM signal obtained by sinusoidal modulation to a depth of modulation equal to 1, has been recovered. The percentage saving in power is

Options :

88039644365. ✘ 33.33

88039644366. ✘ 50

88039644367. ✔ 66.66

88039644368. ✘ 100

Question Number : 53 Question Id : 88039611093 Question Type : MCQ Option Shuffling : Yes Display Question Number : Yes Is Question Mandatory : No Single Line Question Option : No Option Orientation : Vertical

Correct Marks : 1 Wrong Marks : 0

When the modulation index is halved, it is found that the antenna current (r.m.s. value) is also halved. The type of modulation used is

Options :

88039644369. ✖ AM (carrier plus both sidebands)

88039644370. ✖ Single sideband plus carrier

88039644371. ✔ SSB-SC

88039644372. ✖ Vestigial sideband

Question Number : 54 Question Id : 88039611094 Question Type : MCQ Option Shuffling : Yes Display Question Number : Yes Is Question Mandatory : No Single Line Question Option : No Option Orientation : Vertical

Correct Marks : 1 Wrong Marks : 0

To produce frequency modulation using a phase modulator

Options :

88039644373. ✔ The message signal must be integrated and then used for modulation

88039644374. ✖ The message signal must be differentiated and then used for modulation

88039644375. ✖ The phase-modulated signal must be integrated

88039644376. ✖ The phase-modulated signal must be differentiated

Question Number : 55 Question Id : 88039611095 Question Type : MCQ Option Shuffling : Yes Display Question Number : Yes Is Question Mandatory : No Single Line Question Option : No Option Orientation : Vertical

Correct Marks : 1 Wrong Marks : 0

The distortion in the signal arising from aperture effect, can be reduced by

Options :

88039644377. ✓ Reducing the width of the pulses used for flat-top sampling

88039644378. ✘ Reducing the sampling frequency

88039644379. ✘ Properly band-limiting the signal before sampling it

88039644380. ✘ Using flat-top sampling

Question Number : 56 Question Id : 88039611096 Question Type : MCQ Option Shuffling : Yes Display Question Number : Yes Is Question Mandatory : No Single Line Question Option : No Option Orientation : Vertical Correct Marks : 1 Wrong Marks : 0

The independence looking into nodes 1 and 2 in the given circuit in (ohm)

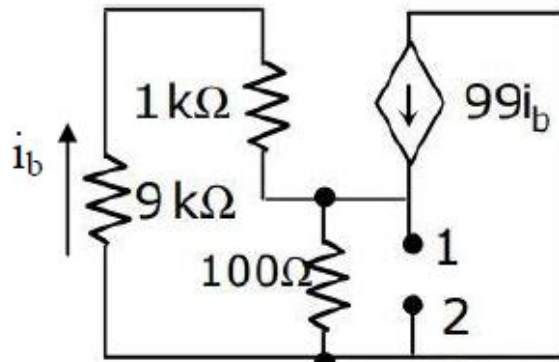

Options :

88039644381. ✘ 100

88039644382. ✘ 5

88039644383. ✘ 0.5

88039644384. ✓ 50

Question Number : 57 Question Id : 88039611097 Question Type : MCQ Option Shuffling : Yes Display Question Number : Yes Is Question Mandatory : No Single Line Question Option : No Option Orientation : Vertical Correct Marks : 1 Wrong Marks : 0

The equivalent inductance measured between the terminals 1 and 2 for the circuit shown in figure is

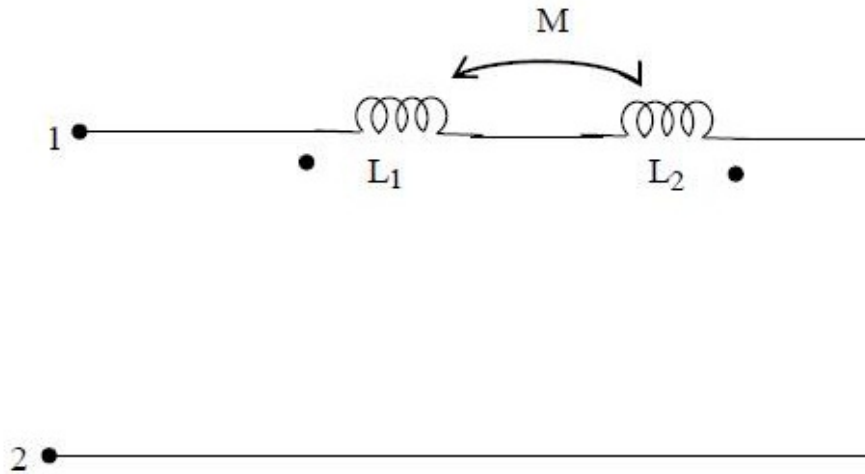

Options :

88039644385. ✗ $L_1 + L_2 + M$

88039644386. ✗ $L_1 + L_2 + 2M$

88039644387. ✗ $L_1 + L_2 - M$

88039644388. ✓ $L_1 + L_2 - 2M$

Question Number : 58 Question Id : 88039611098 Question Type : MCQ Option Shuffling : Yes Display Question Number : Yes Is Question Mandatory : No Single Line Question Option : No Option Orientation : Vertical

Correct Marks : 1 Wrong Marks : 0

An RLC circuit has a resonance frequency of 160 kHz and band width is 0.8 kHz its Q-factor is

Options :

88039644389. ✓ 200

88039644390. ✗ 20

88039644391. ✗ 1

88039644392. ✗ 100

Question Number : 59 Question Id : 88039611099 Question Type : MCQ Option Shuffling : Yes Display Question Number : Yes Is Question Mandatory : No Single Line Question Option : No Option Orientation : Vertical

Correct Marks : 1 Wrong Marks : 0

What is the phase angle (in degree) of voltage and current of the certain ac circuit has resistance of 10 ohms and impendence of 20 ohms ?

Options :

88039644393. ✓ 60

88039644394. ✗ 30

88039644395. ✗ 90

88039644396. ✗ 45

Question Number : 60 Question Id : 88039611100 Question Type : MCQ Option Shuffling : Yes Display Question Number : Yes Is Question Mandatory : No Single Line Question Option : No Option Orientation : Vertical

Correct Marks : 1 Wrong Marks : 0

An electric current in a circuit is given by $I(s) = (2s+8) / (s^2 + 4s + 12)$. If the electric current flows through the 5 ohms resistor, find power dissipated at $t = 0$.

Options :

88039644397. ✖ 10W

88039644398. ✖ 15W

88039644399. ✖ 40W

88039644400. ✔ 20W

Question Number : 61 Question Id : 88039611101 Question Type : MCQ Option Shuffling : Yes Display Question Number : Yes Is Question Mandatory : No Single Line Question Option : No Option Orientation : Vertical Correct Marks : 1 Wrong Marks : 0

A circuit whose resistance is 1Ω to a load of 500Ω in which the energy is supplied from a source, the source will be

Options :

88039644401. ✔ Voltage source

88039644402. ✖ Current source

88039644403. ✖ Power source

88039644404. ✖ Both voltage & current source

Question Number : 62 Question Id : 88039611102 Question Type : MCQ Option Shuffling : Yes Display Question Number : Yes Is Question Mandatory : No Single Line Question Option : No Option Orientation : Vertical

Correct Marks : 1 Wrong Marks : 0

Given the unity feedback system with $G(s) = \frac{K}{s(s+6)}$, the value of K for damping ratio of 0.75 is

Options :

88039644405. ✖ 1

88039644406. ✖ 4

88039644407. ✔ 16

88039644408. ✖ 64

Question Number : 63 Question Id : 88039611103 Question Type : MCQ Option Shuffling : Yes Display Question Number : Yes Is Question Mandatory : No Single Line Question Option : No Option Orientation : Vertical

Correct Marks : 1 Wrong Marks : 0

A controller transfer function is given by $C(s) = 0.1(1 + 2s)/(1 + 0.2s)$. What is its nature and parameter ?

Options :

88039644409. ✖ Lag compensator, $\beta = 10$

88039644410. ✖ Lead compensator, $\alpha = 0.2$

88039644411. ✖ Lag compensator, $\beta = 2$

88039644412. ✔ Lead compensator, $\alpha = 0.1$

Question Number : 64 Question Id : 88039611104 Question Type : MCQ Option Shuffling : Yes Display Question Number : Yes Is Question Mandatory : No Single Line Question Option : No Option Orientation : Vertical

Correct Marks : 1 Wrong Marks : 0

Which one of the following techniques is utilized to determine the actual point at which the root locus crosses the imaginary axis ?

Options :

88039644413. ✘ Nyquist technique

88039644414. ✔ Routh-hurwitz criterion

88039644415. ✘ Nicholas criterion

88039644416. ✘ Bode technique

Question Number : 65 Question Id : 88039611105 Question Type : MCQ Option Shuffling : Yes Display Question Number : Yes Is Question Mandatory : No Single Line Question Option : No Option Orientation : Vertical Correct Marks : 1 Wrong Marks : 0

What will be the stability for the following transfer function?

$$G(s) = 50/s(s+5)$$

Options :

88039644417. ✘ Unstable

88039644418. ✘ Marginally stable

88039644419. ✔ Stable

88039644420. ✘ Critically stable

Question Number : 66 Question Id : 88039611106 Question Type : MCQ Option Shuffling : Yes Display Question Number : Yes Is Question Mandatory : No Single Line Question Option : No Option Orientation : Vertical

Correct Marks : 1 Wrong Marks : 0

Consider the figure shown below which is a portion of a larger electrical network

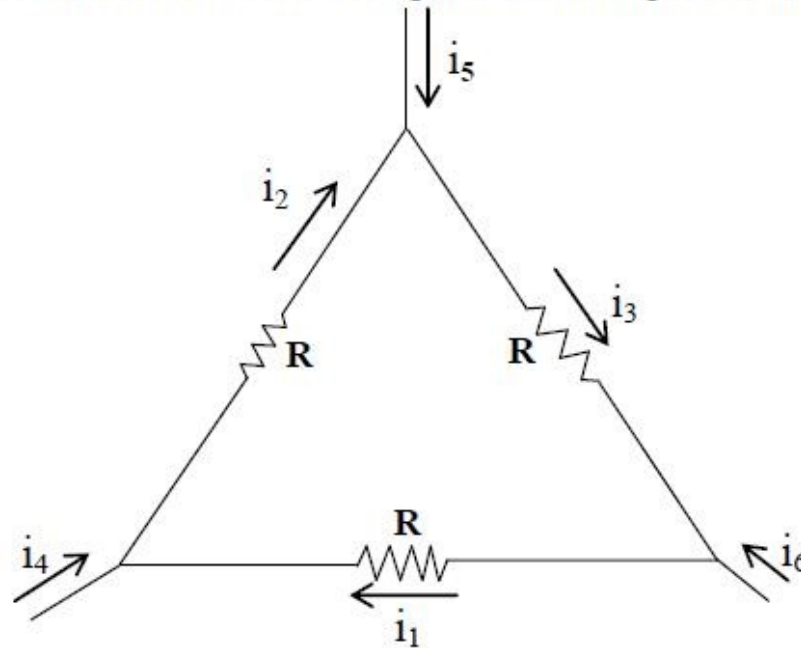

For $R = 1 \Omega$ and currents $i_1 = 2A$, $i_4 = -1A$, $i_5 = -4A$, which one of the following is TRUE ?

Options :

88039644421. ✓ $i_6 = 5A$

88039644422. ✗ $i_3 = -4A$

88039644423. ✗ Data is insufficient

88039644424. ✗ $i_2 = 0$

Mandatory : No Single Line Question Option : No Option Orientation : Vertical

Correct Marks : 1 Wrong Marks : 0

The step response of the system described by the differential equation $dy/dx + 6y = x(t)$ will be

Options :

88039644425. ✓ $(1/6) \times (1 - e^{-6t})$

88039644426. ✗ $e^{-3t} u(t)$

88039644427. ✗ e^{6t}

88039644428. ✗ $6 e^{-6t}$

Question Number : 68 Question Id : 88039611108 Question Type : MCQ Option Shuffling : Yes Display Question Number : Yes Is Question

Mandatory : No Single Line Question Option : No Option Orientation : Vertical

Correct Marks : 1 Wrong Marks : 0

A second order control system is defined by the following equation:

$$4 \frac{d^2c(t)}{dt^2} + 8 \frac{dc(t)}{dt} + 16 c(t) = 16 u(t)$$

The damping ratio and natural frequency for this system are respectively

Options :

88039644429. ✗ 0.25 and 2 rad/s

88039644430. ✗ 0.25 and 4 rad/s

88039644431. ✓ 0.50 and 2 rad/s

88039644432. ✗ 0.50 and 4 rad/s

Question Number : 69 Question Id : 88039611109 Question Type : MCQ Option Shuffling : Yes Display Question Number : Yes Is Question Mandatory : No Single Line Question Option : No Option Orientation : Vertical Correct Marks : 1 Wrong Marks : 0

Given the transfer function of a system. Which of the following characteristics does it have?

$$G(s) = \frac{121}{(s^2 + 13.2s + 121)}$$

Options :

88039644433. ✖ Over damped

88039644434. ✖ Critical damped

88039644435. ✔ Under damped

88039644436. ✖ Can be overdamped or under damped

Question Number : 70 Question Id : 88039611110 Question Type : MCQ Option Shuffling : Yes Display Question Number : Yes Is Question Mandatory : No Single Line Question Option : No Option Orientation : Vertical Correct Marks : 1 Wrong Marks : 0

Let P = Number of open loop poles = 3 and Z = Number of open loop zeros=2 then, find the number of branches terminating at ∞ .

Options :

88039644437. ✖ 5

88039644438. ✔ 1

88039644439. ✖ 3

88039644440. ✖ 2

Question Number : 71 Question Id : 88039611111 Question Type : MCQ Option Shuffling : Yes Display Question Number : Yes Is Question Mandatory : No Single Line Question Option : No Option Orientation : Vertical

Correct Marks : 1 Wrong Marks : 0

Consider a network function $H(s) = \frac{2(s+3)}{(s+2)(s+4)}$. What is the steady state response due to step input?

Options :

88039644441. ✖ $\frac{4}{3}$

88039644442. ✖ $\frac{1}{2}$

88039644443. ✖ 1

88039644444. ✔ $\frac{3}{4}$

Question Number : 72 Question Id : 88039611112 Question Type : MCQ Option Shuffling : Yes Display Question Number : Yes Is Question Mandatory : No Single Line Question Option : No Option Orientation : Vertical

Correct Marks : 1 Wrong Marks : 0

The system function $N(s) = \frac{V(s)}{I(s)} = \frac{(s+3)}{(4s+5)}$. The system is initially at rest. If the excitation $i(t)$ is a unit step, which of the following is the initial value?

Options :

88039644445. ✖ 0

88039644446. ✖ $\frac{3}{5}$

88039644447. ✔ $\frac{1}{4}$

88039644448. ✖ 3/9

Question Number : 73 Question Id : 88039611113 Question Type : MCQ Option Shuffling : Yes Display Question Number : Yes Is Question Mandatory : No Single Line Question Option : No Option Orientation : Vertical

Correct Marks : 1 Wrong Marks : 0

A system has poles at 0.01 Hz, 1 Hz and 80 Hz; zeros at 5 Hz, 100 Hz and 200 Hz. The approximate phase of the system response at 20 Hz is

Options :

88039644449. ✖ 90°

88039644450. ✖ 180°

88039644451. ✔ -90°

88039644452. ✖ -180°

Question Number : 74 Question Id : 88039611114 Question Type : MCQ Option Shuffling : Yes Display Question Number : Yes Is Question Mandatory : No Single Line Question Option : No Option Orientation : Vertical

Correct Marks : 1 Wrong Marks : 0

How many T states are required for the execution of STA 7000H instruction?

Options :

88039644453. ✔ 13

88039644454. ✖ 11

88039644455. ✖ 10

88039644456. ✖ 12

Question Number : 75 Question Id : 88039611115 Question Type : MCQ Option Shuffling : Yes Display Question Number : Yes Is Question Mandatory : No Single Line Question Option : No Option Orientation : Vertical Correct Marks : 1 Wrong Marks : 0

The contents of the HL register pair after the execution of the following program on 8085 are_____

```
LXI H, 3055H
LXI B, 8EBFH
PUSH B
XTHL
POP H
HLT
```

Options :

88039644457. ✖ 8EBFH

88039644458. ✖ 8FBDH

88039644459. ✔ 3055H

88039644460. ✖ 3054H

Question Number : 76 Question Id : 88039611116 Question Type : MCQ Option Shuffling : Yes Display Question Number : Yes Is Question Mandatory : No Single Line Question Option : No Option Orientation : Vertical Correct Marks : 1 Wrong Marks : 0

Which of the following instruction will never affect the sign flag?

Options :

88039644461. ✖ DCR R

88039644462. ✖ ORA R

88039644463. ✓ DCX Rp

88039644464. ✘ XRA R

Question Number : 77 Question Id : 88039611117 Question Type : MCQ Option Shuffling : Yes Display Question Number : Yes Is Question Mandatory : No Single Line Question Option : No Option Orientation : Vertical Correct Marks : 1 Wrong Marks : 0

The drain of n channel MOSFET is shorted to gate so that $V_{gs}=V_{ds}$. The threshold voltage of MOSFET is 1V. If the drain current is 1mA for $V_{gs}=2V$, then for $V_{gs}=3V$, I_D will be

Options :

88039644465. ✘ 2mA

88039644466. ✘ 3mA

88039644467. ✓ 4mA

88039644468. ✘ 9mA

Question Number : 78 Question Id : 88039611118 Question Type : MCQ Option Shuffling : Yes Display Question Number : Yes Is Question Mandatory : No Single Line Question Option : No Option Orientation : Vertical Correct Marks : 1 Wrong Marks : 0

According to voltage transfer curve of CMOS inverter, V_{IL} is

Options :

88039644469. ✘ Minimum output voltage when input is logic 0

88039644470. ✘ Minimum input voltage which can be read as logic 1

88039644471. ✘ Maximum output voltage when input is logic 1

88039644472. ✔ Maximum input voltage which can be read as logic 0

Question Number : 79 Question Id : 88039611119 Question Type : MCQ Option Shuffling : Yes Display Question Number : Yes Is Question Mandatory : No Single Line Question Option : No Option Orientation : Vertical Correct Marks : 1 Wrong Marks : 0

What is the simplified expression for $z = AB'C' + AB'C + ABC$ is

Options :

88039644473. ✔ $A(B' + C)$

88039644474. ✘ $A'(B + C)$

88039644475. ✘ AC'

88039644476. ✘ $A(B + C)$

Question Number : 80 Question Id : 88039611120 Question Type : MCQ Option Shuffling : Yes Display Question Number : Yes Is Question Mandatory : No Single Line Question Option : No Option Orientation : Vertical Correct Marks : 1 Wrong Marks : 0

The logic function implemented by the following circuit is

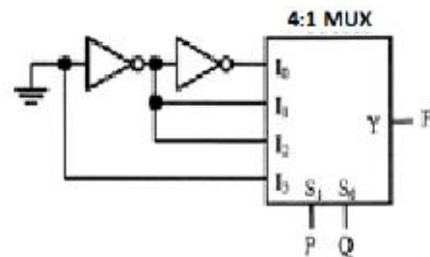

Options :

88039644477. ✘ $F = \text{AND}(P, Q)$

88039644478. ✘ $F = \text{OR}(P, Q)$

88039644479. ✘ $F = \text{XNOR}(P, Q)$

88039644480. ✔ $F = \text{XOR}(P, Q)$

Question Number : 81 Question Id : 88039611121 Question Type : MCQ Option Shuffling : Yes Display Question Number : Yes Is Question Mandatory : No Single Line Question Option : No Option Orientation : Vertical

Correct Marks : 1 Wrong Marks : 0

The input combination needed to produce $x = 1$ in the circuit shown is

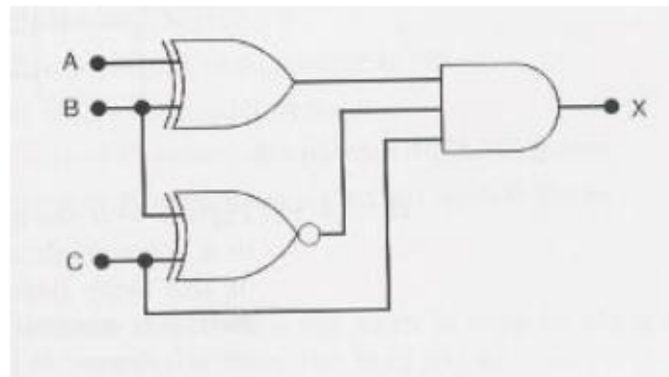

Options :

88039644481. ✔ $A=0; B=1; C=1$

88039644482. ✘ $A=1; B=0; C=0$

88039644483. ✘ $A=0; B=0; C=1$

88039644484. ✖ A=1; B=1; C=1

Question Number : 82 Question Id : 88039611122 Question Type : MCQ Option Shuffling : Yes Display Question Number : Yes Is Question Mandatory : No Single Line Question Option : No Option Orientation : Vertical

Correct Marks : 1 Wrong Marks : 0

The number of full and half-adders required to add 32-bit numbers is

Options :

88039644485. ✖ 16 half-adders, 16 full-adders

88039644486. ✔ 1 half-adder, 31 full-adders

88039644487. ✖ 32 half-adders, 0 full-adders

88039644488. ✖ 8 half-adders, 24 full-adders

Question Number : 83 Question Id : 88039611123 Question Type : MCQ Option Shuffling : Yes Display Question Number : Yes Is Question Mandatory : No Single Line Question Option : No Option Orientation : Vertical

Correct Marks : 1 Wrong Marks : 0

A one-to-four line demultiplexer is to be implemented using a memory. How many bits must each word have?

Options :

88039644489. ✔ 1 bit

88039644490. ✖ 2 bits

88039644491. ✖ 4 bits

88039644492. ✖ 8 bits

Question Number : 84 Question Id : 88039611124 Question Type : MCQ Option Shuffling : Yes Display Question Number : Yes Is Question Mandatory : No Single Line Question Option : No Option Orientation : Vertical

Correct Marks : 1 Wrong Marks : 0

How many lines the truth table for a four-input NAND gate would contain to cover all possible input combinations?

Options :

88039644493. ✖ 4

88039644494. ✖ 8

88039644495. ✖ 12

88039644496. ✔ 16

Question Number : 85 Question Id : 88039611125 Question Type : MCQ Option Shuffling : Yes Display Question Number : Yes Is Question Mandatory : No Single Line Question Option : No Option Orientation : Vertical

Correct Marks : 1 Wrong Marks : 0

A sequential circuit using D flip-flop and logic gates is shown in fig. where X and Y are the inputs and Z is output. The circuit is

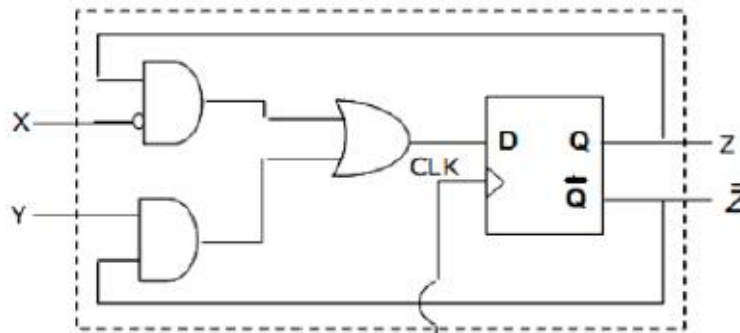

Options :

88039644497. ✖ SR flipflop with inputs X=R and Y=S

88039644498. ✖ SR flipflop with inputs X=S and Y=R

88039644499. ✖ JK flipflop with inputs X=J and Y=K

88039644500. ✔ JK flipflop with inputs X=K and Y=J

Question Number : 86 Question Id : 88039611126 Question Type : MCQ Option Shuffling : Yes Display Question Number : Yes Is Question Mandatory : No Single Line Question Option : No Option Orientation : Vertical

Correct Marks : 1 Wrong Marks : 0

The race around condition, in the following circuit;

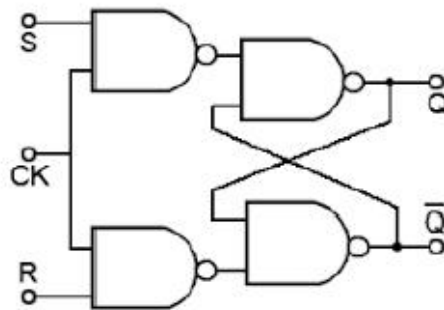

Options :

88039644501. ✔ Does not occur

88039644502. ✖ Occurs when CLK = 0

88039644503. ✖ Occurs when CLK = 1 ; S= R =1

88039644504. ✖ Occurs when CLK = 1; S= R = 0

Question Number : 87 Question Id : 88039611127 Question Type : MCQ Option Shuffling : Yes Display Question Number : Yes Is Question Mandatory : No Single Line Question Option : No Option Orientation : Vertical Correct Marks : 1 Wrong Marks : 0

The input frequency for the FF given is 1 KHz, then what will be output frequency

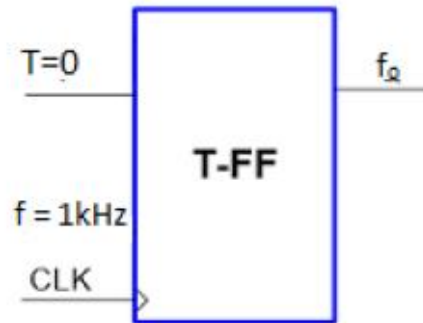

Options :

88039644505. ✘ 50 Hz

88039644506. ✘ 1 kHz

88039644507. ✔ 0 Hz

88039644508. ✘ 2 KHz

Question Number : 88 Question Id : 88039611128 Question Type : MCQ Option Shuffling : Yes Display Question Number : Yes Is Question Mandatory : No Single Line Question Option : No Option Orientation : Vertical Correct Marks : 1 Wrong Marks : 0

Total number of instructions in 8085 microprocessor assembly language is

Options :

88039644509. ✘ 244

88039644510. ✘ 247

88039644511. ✖ 245

88039644512. ✔ 246

Question Number : 89 Question Id : 88039611129 Question Type : MCQ Option Shuffling : Yes Display Question Number : Yes Is Question Mandatory : No Single Line Question Option : No Option Orientation : Vertical Correct Marks : 1 Wrong Marks : 0

In an 8085 microprocessor the number of address lines required to access a 32 Kbyte memory bank is

Options :

88039644513. ✖ 12

88039644514. ✔ 15

88039644515. ✖ 13

88039644516. ✖ 16

Question Number : 90 Question Id : 88039611130 Question Type : MCQ Option Shuffling : Yes Display Question Number : Yes Is Question Mandatory : No Single Line Question Option : No Option Orientation : Vertical Correct Marks : 1 Wrong Marks : 0

The number of hardware interrupts (which require an external signal to interrupt) present in an 8085 microprocessor are

Options :

88039644517. ✖ 1

88039644518. ✔ 5

88039644519. ✖ 12

88039644520. ✖ 13

Question Number : 91 Question Id : 88039611131 Question Type : MCQ Option Shuffling : Yes Display Question Number : Yes Is Question Mandatory : No Single Line Question Option : No Option Orientation : Vertical

Correct Marks : 1 Wrong Marks : 0

The Fourier series of a periodic signal $x(t)$ with period T will not converge if

Options :

88039644521. ✔ $|x(t)|$ is not finite at all values of t

88039644522. ✖ $x(t)$ has more than one maxima in one period T

88039644523. ✖ $x(t)$ is not continuous at all points

88039644524. ✖ $x(t)$ is not a band-limited signal

Question Number : 92 Question Id : 88039611132 Question Type : MCQ Option Shuffling : Yes Display Question Number : Yes Is Question Mandatory : No Single Line Question Option : No Option Orientation : Vertical

Correct Marks : 1 Wrong Marks : 0

The following five instructions were executed on an 8085 microprocessor.

MVI A, 33H

MVI B, 78H

ADD B

CMA

ANI 52H

The Accumulator value immediately after the execution of the fifth instruction is

Options :

88039644525. ✖ 35H

88039644526. ✓ 50H

88039644527. ✗ 41H

88039644528. ✗ 22H

Question Number : 93 Question Id : 88039611133 Question Type : MCQ Option Shuffling : Yes Display Question Number : Yes Is Question Mandatory : No Single Line Question Option : No Option Orientation : Vertical Correct Marks : 1 Wrong Marks : 0

In an 8085 system, a PUSH operation requires more clock cycles than a POP operation.

Which one of the following options is the correct reason for this?

Options :

88039644529. ✗ For POP the transceivers remain in the same direction as for instruction fetch (Memory to Processor), whereas for PUSH their direction has to be reversed.

88039644530. ✗ Memory write operations are slower than memory read operations in 8085 based system.

88039644531. ✓ The stack pointer needs to be pre-decremented before writing registers in a PUSH, whereas POP operation uses the address already in the stack pointer.

88039644532. ✗ Order of registers has to be interchanged for a PUSH operation, whereas POP uses their natural order.

Question Number : 94 Question Id : 88039611134 Question Type : MCQ Option Shuffling : Yes Display Question Number : Yes Is Question Mandatory : No Single Line Question Option : No Option Orientation : Vertical Correct Marks : 1 Wrong Marks : 0

An 8085 Assembly language program is given below. Assume that the carry flag is initially unset. The content of the accumulator after the execution of the program is,

```
MVI A,07H  
RLC  
MOV B,A  
RLC  
RLC  
ADD B
```

Options :

88039644533. ✖ 32CH

88039644534. ✖ 64H

88039644535. ✔ 46H

88039644536. ✖ 56H

Question Number : 95 Question Id : 88039611135 Question Type : MCQ Option Shuffling : Yes Display Question Number : Yes Is Question Mandatory : No Single Line Question Option : No Option Orientation : Vertical Correct Marks : 1 Wrong Marks : 0

An I/O peripheral device shown in figure (b) below is to be interfaced to an 8085 microprocessor. To select the I/O device in the I/O address range DCH – DFH, its chip-select (\overline{CS}) should be connected to the output of the decoder shown in figure (a) below

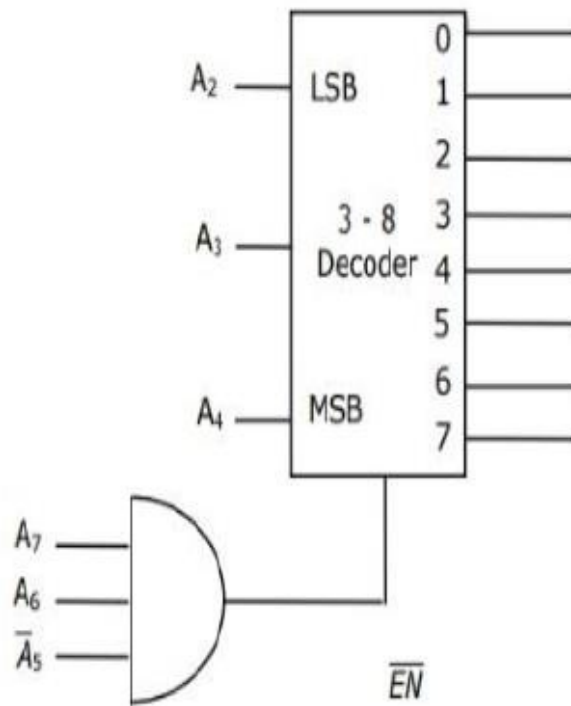

Fig. (a)

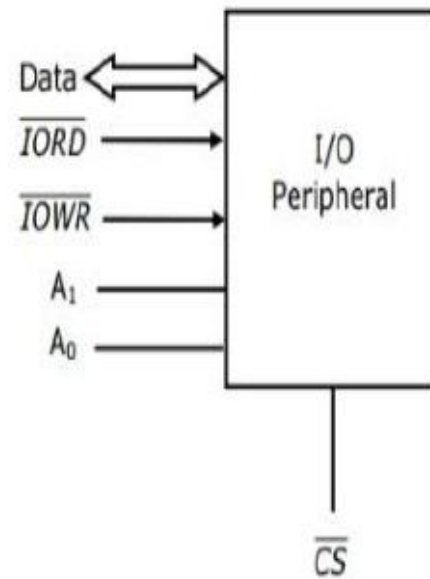

Fig. (b)

Options :

88039644537. ✓ Output 7

88039644538. ✗ Output 5

88039644539. ✗ Output 2

88039644540. ✖ Output 0

Question Number : 96 Question Id : 88039611136 Question Type : MCQ Option Shuffling : Yes Display Question Number : Yes Is Question Mandatory : No Single Line Question Option : No Option Orientation : Vertical

Correct Marks : 1 Wrong Marks : 0

The LTI system with $h(t) = e^{-t}$, $-\infty < t < \infty$ is

Options :

88039644541. ✖ Causal and stable

88039644542. ✖ Causal and unstable

88039644543. ✖ Non-causal and stable

88039644544. ✔ Non-causal and unstable

Question Number : 97 Question Id : 88039611137 Question Type : MCQ Option Shuffling : Yes Display Question Number : Yes Is Question Mandatory : No Single Line Question Option : No Option Orientation : Vertical

Correct Marks : 1 Wrong Marks : 0

Two LTI systems with impulse responses $h_1(t)$ and $h_2(t)$ are connected in series (cascade), the impulse response of the overall system is

Options :

88039644545. ✖ $h_1(t) + h_2(t)$

88039644546. ✖ $h_1(t)h_2(t) / (h_1(t) + h_2(t))$

88039644547. ✔ $h_1(t) * h_2(t)$

88039644548. ✖ $h_1(t) \cdot h_2(t)$

Question Number : 98 Question Id : 88039611138 Question Type : MCQ Option Shuffling : Yes Display Question Number : Yes Is Question Mandatory : No Single Line Question Option : No Option Orientation : Vertical
Correct Marks : 1 Wrong Marks : 0

If $CS = A_{15} \overline{A_{14}} A_{13}$ is used as the chip select logic of a 4K RAM in an 8085 system, then its memory range will be

Options :

88039644549. ✘ A000H-AFFFH

88039644550. ✘ 9000H-BFFFH

88039644551. ✘ 9000H-9FFFH and A000H-AFFFH

88039644552. ✔ A000H-AFFFH and B000H-BFFFH

Question Number : 99 Question Id : 88039611139 Question Type : MCQ Option Shuffling : Yes Display Question Number : Yes Is Question Mandatory : No Single Line Question Option : No Option Orientation : Vertical
Correct Marks : 1 Wrong Marks : 0

In the 8085 microprocessor, the RST5 instruction transfers the program execution to the following location

Options :

88039644553. ✘ 30H

88039644554. ✘ 24H

88039644555. ✔ 28H

88039644556. ✘ 60H

Question Number : 100 Question Id : 88039611140 Question Type : MCQ Option Shuffling : Yes Display Question Number : Yes Is Question Mandatory : No Single Line Question Option : No Option Orientation : Vertical

Correct Marks : 1 Wrong Marks : 0

An I/O processor control the flow of information between

Options :

88039644557. ✘ Cache memory and I/O devices

88039644558. ✔ Main memory and I/O devices

88039644559. ✘ Two I/O devices

88039644560. ✘ Cache and main memories

Question Number : 101 Question Id : 88039611141 Question Type : MCQ Option Shuffling : Yes Display Question Number : Yes Is Question Mandatory : No Single Line Question Option : No Option Orientation : Vertical

Correct Marks : 1 Wrong Marks : 0

In a microprocessor, when a CPU is interrupted, it

Options :

88039644561. ✘ Stops execution of instruction

88039644562. ✘ Acknowledges interrupts and branches of subroutine

88039644563. ✘ Acknowledges interrupt and continues

88039644564. ✔ Acknowledges interrupt and waits for the new instruction from the interrupting device

Question Number : 102 Question Id : 88039611142 Question Type : MCQ Option Shuffling : Yes Display Question Number : Yes Is Question Mandatory : No Single Line Question Option : No Option Orientation : Vertical Correct Marks : 1 Wrong Marks : 0

In a microcomputer, wait states are used to

Options :

- 88039644565. ✘ Make the processor wait during a DMA operation
- 88039644566. ✘ Make the processor wait during an interrupt processing
- 88039644567. ✘ Make the processor wait during a power shutdown
- 88039644568. ✔ Interface slow peripherals to the processor

Question Number : 103 Question Id : 88039611143 Question Type : MCQ Option Shuffling : Yes Display Question Number : Yes Is Question Mandatory : No Single Line Question Option : No Option Orientation : Vertical Correct Marks : 1 Wrong Marks : 0

A band limited low pass signal is sampled at twice its Nyquist rate with $f_s = 2000$ sps.

The signal is band limited to

Options :

- 88039644569. ✘ 250 Hz
- 88039644570. ✘ 1000 Hz
- 88039644571. ✔ 500 Hz
- 88039644572. ✘ 2000 Hz

Question Number : 104 Question Id : 88039611144 Question Type : MCQ Option Shuffling : Yes Display Question Number : Yes Is Question

Mandatory : No Single Line Question Option : No Option Orientation : Vertical

Correct Marks : 1 Wrong Marks : 0

The z – transform of $a^n u(n)$ is

Options :

88039644573. ✓ $z/(z-a)$

88039644574. ✗ $z/(z+a)$

88039644575. ✗ $1/(1-az)$

88039644576. ✗ $1/(1+az)$

Question Number : 105 Question Id : 88039611145 Question Type : MCQ Option Shuffling : Yes Display Question Number : Yes Is Question

Mandatory : No Single Line Question Option : No Option Orientation : Vertical

Correct Marks : 1 Wrong Marks : 0

A microprocessor with a 15-bit address bus is used in a linear memory selection configuration (i.e. Address bus lines are directly used as chip selects of memory chips) with 4 memory chips. The maximum addressable memory space is

Options :

88039644577. ✗ 64k

88039644578. ✗ 16k

88039644579. ✗ 8k

88039644580. ✓ 32k

Question Number : 106 Question Id : 88039611146 Question Type : MCQ Option Shuffling : Yes Display Question Number : Yes Is Question Mandatory : No Single Line Question Option : No Option Orientation : Vertical Correct Marks : 1 Wrong Marks : 0

The 8255 Programmable Peripheral Interface is used as described below.

- I. An A/D converter is interfaced to a microprocessor through an 8255. The conversion is initiated by a signal from the 8255 on Port C. A signal on Port C causes data to be strobed into Port A.
- II. Two computers exchange data using a pair of 8255s. Port A works as a bidirectional data port supported by appropriate handshaking signals.

The appropriate modes of operation of the 8255 for I and II would be

Options :

88039644581. ✘ Mode 0 for I and Mode 1 for II

88039644582. ✔ Mode 1 for I and Mode 2 for II

88039644583. ✘ Mode 2 for I and Mode 0 for II

88039644584. ✘ Mode 2 for I and Mode 1 for II

Question Number : 107 Question Id : 88039611147 Question Type : MCQ Option Shuffling : Yes Display Question Number : Yes Is Question Mandatory : No Single Line Question Option : No Option Orientation : Vertical Correct Marks : 1 Wrong Marks : 0

The reverse saturation current flowing through a PN junction diode at 25° C is 30 nA,

then its value at 45° C is

Options :

88039644585. ✘ 30 nA

88039644586. ✘ 60 nA

88039644587. ✔ 120 nA

88039644588. ✘ 15 nA

Question Number : 108 Question Id : 88039611148 Question Type : MCQ Option Shuffling : Yes Display Question Number : Yes Is Question Mandatory : No Single Line Question Option : No Option Orientation : Vertical Correct Marks : 1 Wrong Marks : 0

What is the value of ' I_Z ' in the circuit shown

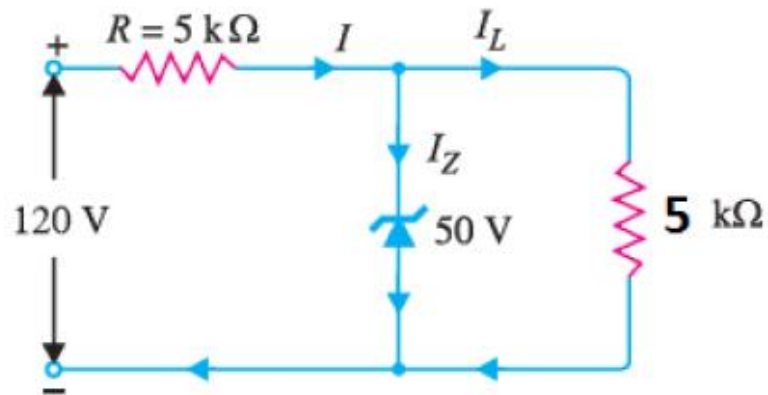

Options :

88039644589. ✘ 14 mA

88039644590. ✔ 4 mA

88039644591. ✘ 10 mA

88039644592. ✘ 0 mA

Question Number : 109 Question Id : 88039611149 Question Type : MCQ Option Shuffling : Yes Display Question Number : Yes Is Question Mandatory : No Single Line Question Option : No Option Orientation : Vertical

Correct Marks : 1 Wrong Marks : 0

The base bias circuit shown in the fig has $R_B = 470 \text{ k}\Omega$, $R_C = 2.2 \text{ k}\Omega$ and $V_{CC} = 18 \text{ V}$.

What is base current (Assume the transistor is made of silicon)

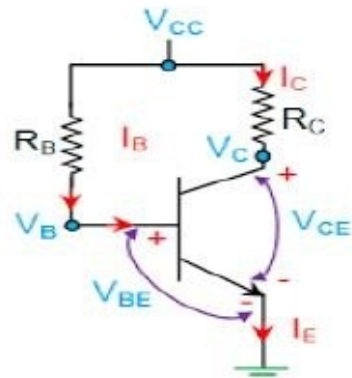

Options :

88039644593. ✘ 36.8 mA

88039644594. ✘ 36.8 A

88039644595. ✔ 36.8 μA

88039644596. ✘ 0 A

Question Number : 110 Question Id : 88039611150 Question Type : MCQ Option Shuffling : Yes Display Question Number : Yes Is Question Mandatory : No Single Line Question Option : No Option Orientation : Vertical

Correct Marks : 1 Wrong Marks : 0

PIN diode can be used as

Options :

88039644597. ✘ Rectifier

88039644598. ✓ RF switch

88039644599. ✗ Oscillator

88039644600. ✗ Amplifier

Question Number : 111 Question Id : 88039611151 Question Type : MCQ Option Shuffling : Yes Display Question Number : Yes Is Question Mandatory : No Single Line Question Option : No Option Orientation : Vertical Correct Marks : 1 Wrong Marks : 0

In Tunnel diode the impurity concentration is in the order of

Options :

88039644601. ✓ 1 in 10^3

88039644602. ✗ 1 in 10^5

88039644603. ✗ 1 in 10^7

88039644604. ✗ 1 in 10^9

Question Number : 112 Question Id : 88039611152 Question Type : MCQ Option Shuffling : Yes Display Question Number : Yes Is Question Mandatory : No Single Line Question Option : No Option Orientation : Vertical Correct Marks : 1 Wrong Marks : 0

The current 'i' in the circuit shown is

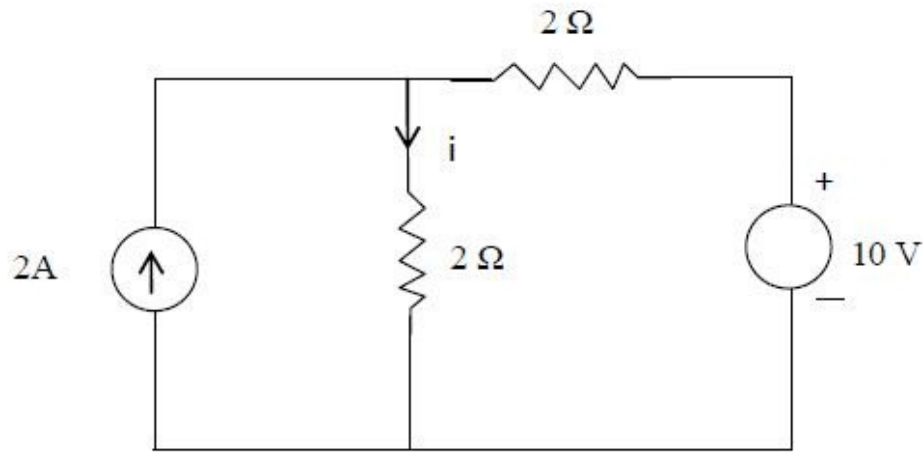

Options :

88039644605. ✘ 2.5 A

88039644606. ✘ 1 A

88039644607. ✔ 3.5 A

88039644608. ✘ 4.5 A

Question Number : 113 Question Id : 88039611153 Question Type : MCQ Option Shuffling : Yes Display Question Number : Yes Is Question Mandatory : No Single Line Question Option : No Option Orientation : Vertical

Correct Marks : 1 Wrong Marks : 0

Superposition theorem is not applicable to networks containing

Options :

88039644609. ✔ Non- linear elements

88039644610. ✘ Dependent voltage sources

88039644611. ✖ Dependent current sources

88039644612. ✖ Independent current sources

Question Number : 114 Question Id : 88039611154 Question Type : MCQ Option Shuffling : Yes Display Question Number : Yes Is Question Mandatory : No Single Line Question Option : No Option Orientation : Vertical Correct Marks : 1 Wrong Marks : 0

For a certain load the true power is 100 W and the reactive power is 100 VAR then the apparent power is

Options :

88039644613. ✖ 200 VA

88039644614. ✖ 100 VA

88039644615. ✔ 141.4 VA

88039644616. ✖ 120 VA

Question Number : 115 Question Id : 88039611155 Question Type : MCQ Option Shuffling : Yes Display Question Number : Yes Is Question Mandatory : No Single Line Question Option : No Option Orientation : Vertical Correct Marks : 1 Wrong Marks : 0

What is the maximum power transferred to the load in the circuit shown

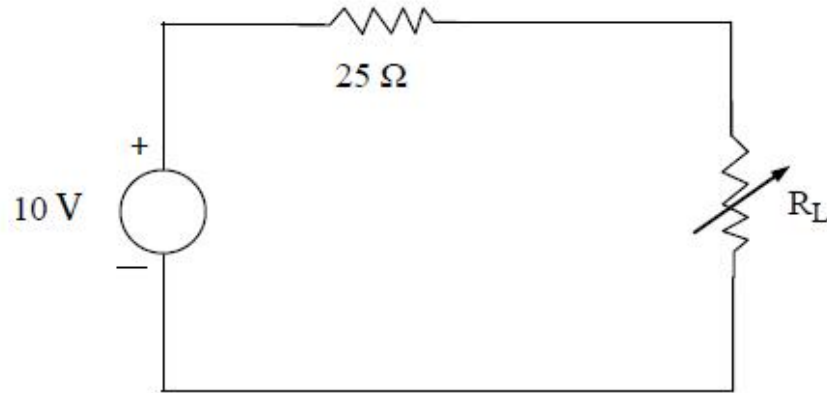

Options :

88039644617. ✖ 5 W

88039644618. ✖ 2.5 W

88039644619. ✔ 10 W

88039644620. ✖ 25 W

Question Number : 116 Question Id : 88039611156 Question Type : MCQ Option Shuffling : Yes Display Question Number : Yes Is Question Mandatory : No Single Line Question Option : No Option Orientation : Vertical Correct Marks : 1 Wrong Marks : 0

A wire is carrying a direct current of 20 A and a sinusoidal alternating current of peak value 20 A. The rms value of resultant current is

Options :

88039644621. ✖ 12.25 A

88039644622. ✖ 10 A

88039644623. ✓ 24.5 A

88039644624. ✘ 30 A

Question Number : 117 Question Id : 88039611157 Question Type : MCQ Option Shuffling : Yes Display Question Number : Yes Is Question Mandatory : No Single Line Question Option : No Option Orientation : Vertical Correct Marks : 1 Wrong Marks : 0

The RMS current in the circuit shown is ($L = 50 \text{ mH}$; $V_{\text{rms}} = 10 \text{ V}$ and $f=10\text{KHz}$)

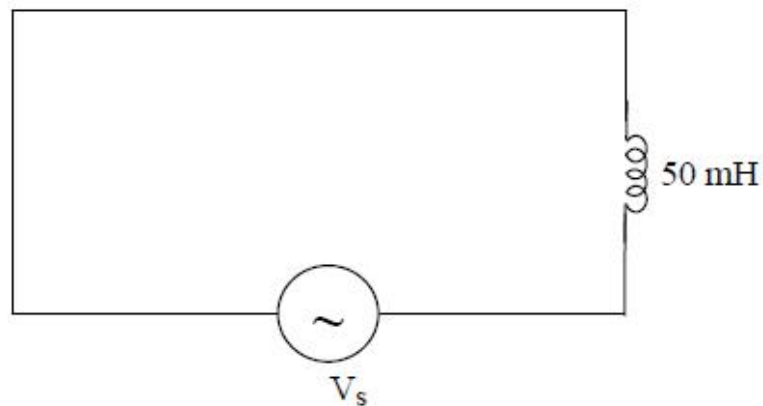

$V_{\text{rms}} = 10 \text{ V}$, $f = 10 \text{ KHz}$

Options :

88039644625. ✓ 3.18 mA

88039644626. ✘ 3.18 A

88039644627. ✘ 31.8 mA

88039644628. ✘ 0.2 mA

Question Number : 118 Question Id : 88039611158 Question Type : MCQ Option Shuffling : Yes Display Question Number : Yes Is Question Mandatory : No Single Line Question Option : No Option Orientation : Vertical

Correct Marks : 1 Wrong Marks : 0

The value of $v(o+)$ for the circuit shown is (the supply voltage is 50 V)

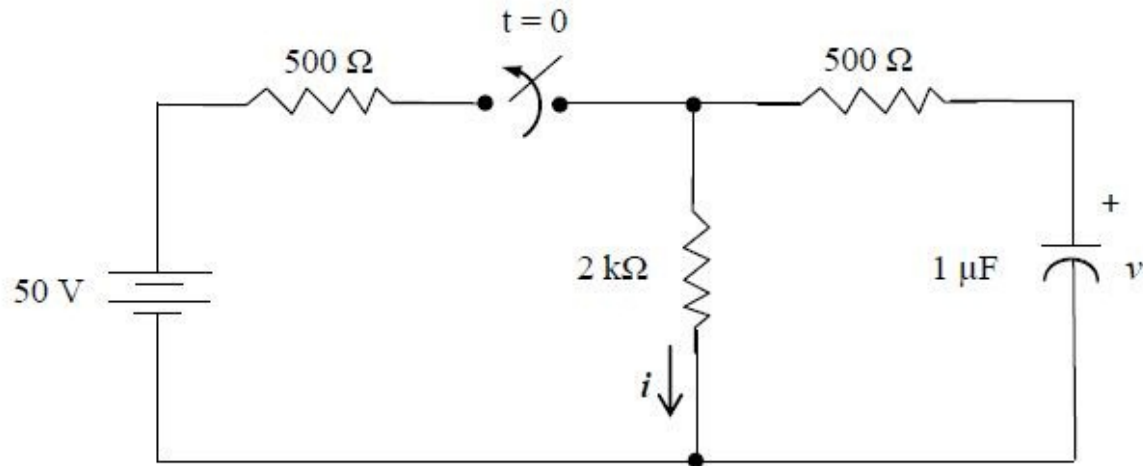

Options :

88039644629. ✘ 50 V

88039644630. ✘ 0 V

88039644631. ✔ 40 V

88039644632. ✘ -50 V

Question Number : 119 Question Id : 88039611159 Question Type : MCQ Option Shuffling : Yes Display Question Number : Yes Is Question Mandatory : No Single Line Question Option : No Option Orientation : Vertical

Correct Marks : 1 Wrong Marks : 0

For a two port bilateral network the three transmission parameters are given by $A = 6/5$,

$B = 17/5$, $C = 1/5$, then the value of D is

Options :

88039644633. ✖ 1

88039644634. ✖ 1/5

88039644635. ✔ 7/5

88039644636. ✖ 5/7

Question Number : 120 Question Id : 88039611160 Question Type : MCQ Option Shuffling : Yes Display Question Number : Yes Is Question Mandatory : No Single Line Question Option : No Option Orientation : Vertical

Correct Marks : 1 Wrong Marks : 0

A silicon PN junction is forward biased with a constant current at room temperature, when the temperature is increased by 10°C , the forward bias voltage across the PN junction is

Options :

88039644637. ✖ Increased by 60 mV

88039644638. ✖ Decreased by 60 mV

88039644639. ✖ Increased by 25 mV

88039644640. ✔ Decreased by 25 mV